

SEQUENCE OF OPERATION 1: "PRODUCT PUMP FILL CYCLE"

FIRST CYCLE: A. VENT VALVE IS OPEN
 B. MATERIAL INLET VALVE OPENS FOR PRE-SET TIME TO LOAD MATERIAL INTO THE PRODUCT PUMP

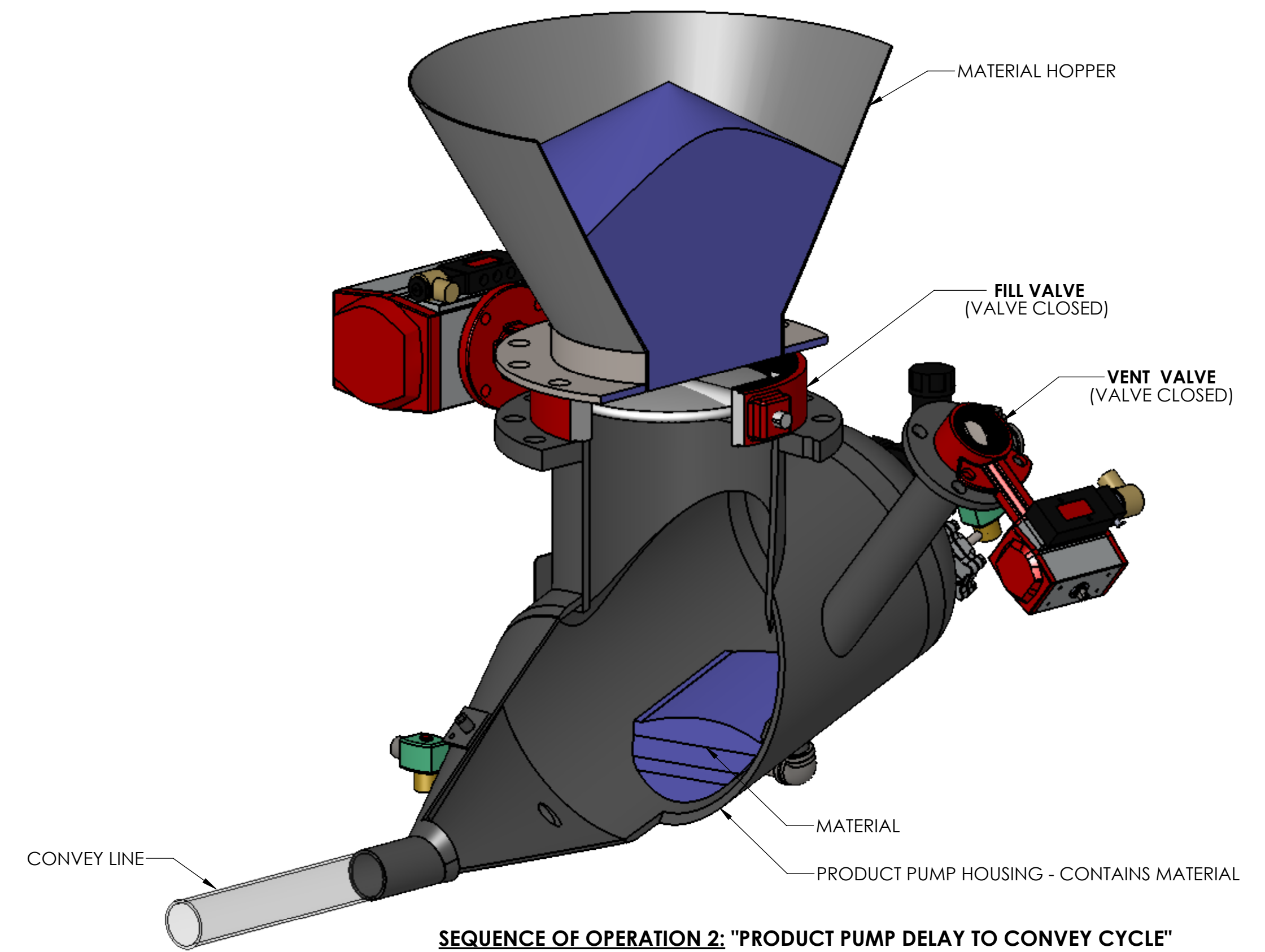

SEQUENCE OF OPERATION 2: "PRODUCT PUMP DELAY TO CONVEY CYCLE"

A. MATERIAL INLET VALVE CLOSSES
 B. VENT VALVE CLOSSES
 C. SHORT TIME DELAY

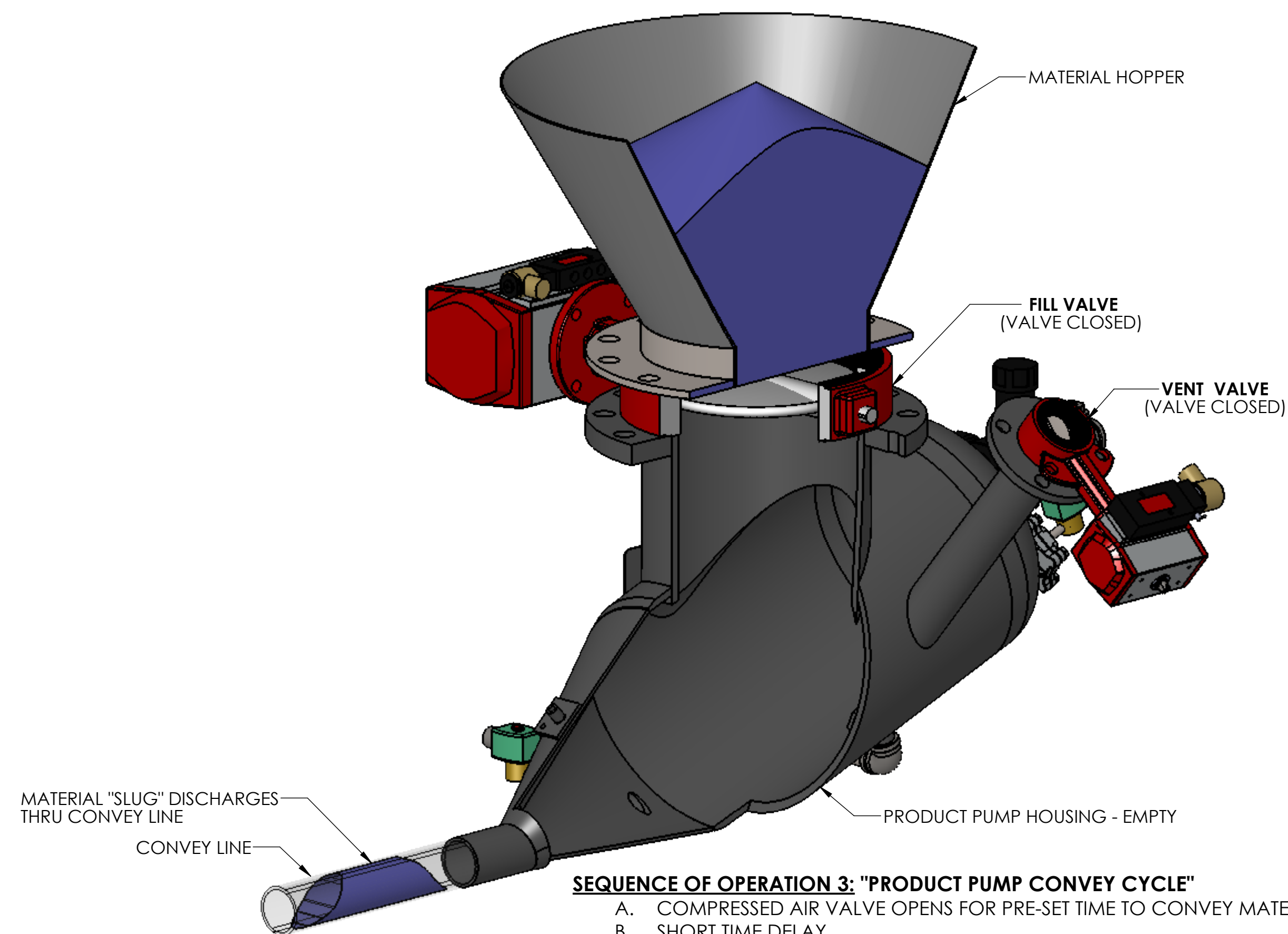

SEQUENCE OF OPERATION 3: "PRODUCT PUMP CONVEY CYCLE"

A. COMPRESSED AIR VALVE OPENS FOR PRE-SET TIME TO CONVEY MATERIAL THROUGH THE CONVEY LINE
 B. SHORT TIME DELAY
 C. VENT VALVE OPENS FOR PRE-SET PERIOD BEFORE OPENING THE INLET VALVE
 D. REPEAT CYCLE BY GOING TO THE PRODUCT PUMP FILL CYCLE, SEQUENCE NO. 1

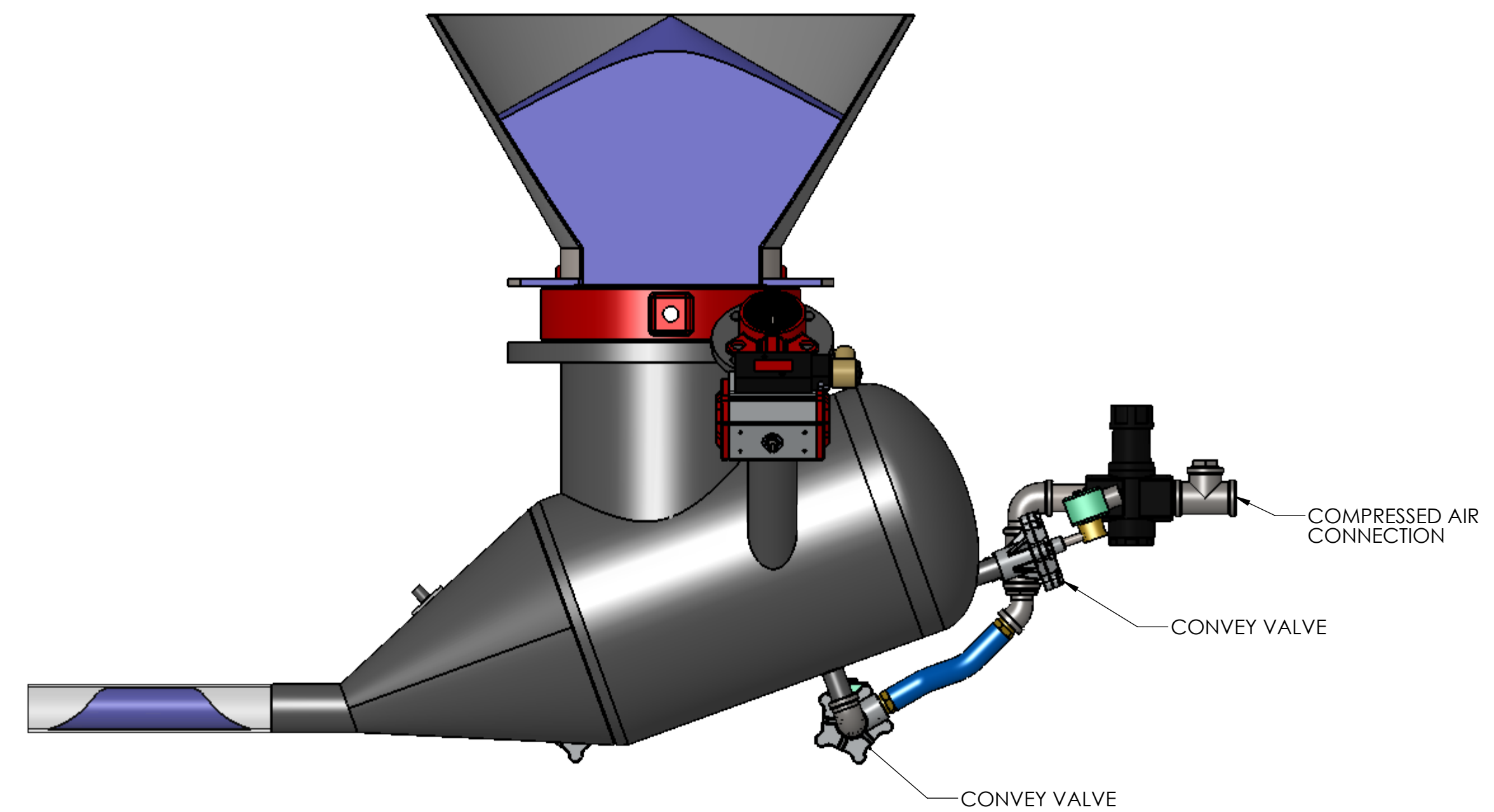

CONVEY VALVE DETAIL

UNIT WEIGHT
 LBS

| GENERAL TOLERANCES | |
|--|-------------------|
| UNLESS OTHERWISE SPECIFIED THE FOLLOWING SHALL APPLY | |
| MACHINING - .XX= .02 .XXX= .005 ANGLE= .50° | |
| SURFACE ROUGHNESS HEIGHT 63 MICRONS OR LESS | |
| FABRICATION - UNDER 6 | 6 TO 24 |
| 24 TO 60 | OVER 60 |
| ± .06 | ± .12 ± .19 ± .25 |
| UNLESS OTHERWISE SPECIFIED DIMENSIONS ARE IN INCHES | |

| REV. NO. | DESCRIPTION | DATE | BY |
|---|-------------|----------------------|------|
| REVISIONS | | | |
| CUSTOMER: * | | | |
| CUSTOMER PO NUMBER: * | | | |
| YOUNG JOB NUMBER: | | | |
| TITLE | | | |
| YOUNG INDUSTRIES PRODUCT PUMP SEQUENCE OF OPERATION | | | |
| | | | |
| DRAWN BY: BMF | | DATE DRAWN: 10/24/16 | |
| CHECKED BY: | | SCALE=1:5 | |
| DRAWING NUMBER | | SHEET | REV: |
| S-20993-00 | | 1 OF 1 | |