

SIZE WORKING CAPACITY(CU.FT.)	A	B	C	D	E	F	G	H	J
15	6'-9 1/4"	4'-0"	4'-2"	0'-6"	3'-4"	1'-3 3/4"	1'-7 1/2"	1'-9 1/4"	9
35	8'-3 1/4"	4'-0"	4'-2"	2'-0"	3'-4"	1'-3 3/4"	1'-7 1/2"	1'-9 1/4"	9
55	9'-10"	4'-6"	4'-9"	3'-2"	3'-8 3/4"	1'-3 3/4"	1'-7 1/2"	1'-9 1/4"	9
75	11'-0"	4'-6"	4'-9"	4'-4"	3'-8 3/4"	1'-3 3/4"	1'-7 1/2"	1'-9 1/4"	9
100	11'-2 1/4"	6'-0"	6'-3"	3'-3"	5'-0"	1'-3 3/4"	1'-7 1/2"	1'-9 1/4"	9
150	13'-8 3/4"	6'-0"	6'-3"	4'-9"	5'-0"	2'-0 3/4"	1'-11"	2'-2 1/4"	12
200	15'-8 3/4"	6'-0"	6'-3"	6'-9"	5'-0"	2'-0 3/4"	1'-11"	2'-2 1/4"	12
300	19'-2 3/4"	6'-0"	6'-3"	10'-3"	5'-0"	2'-0 3/4"	1'-11"	2'-2 1/4"	12

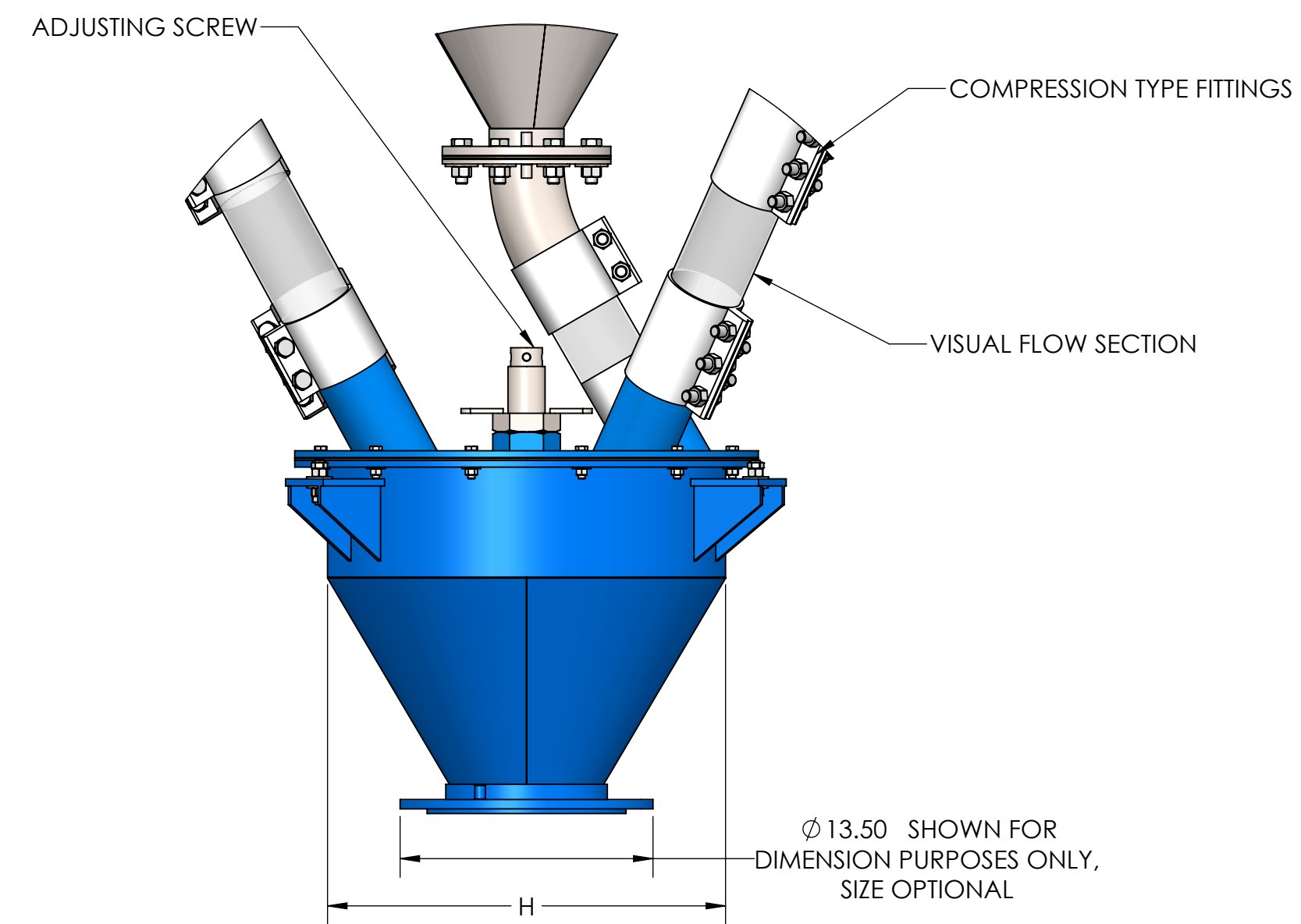
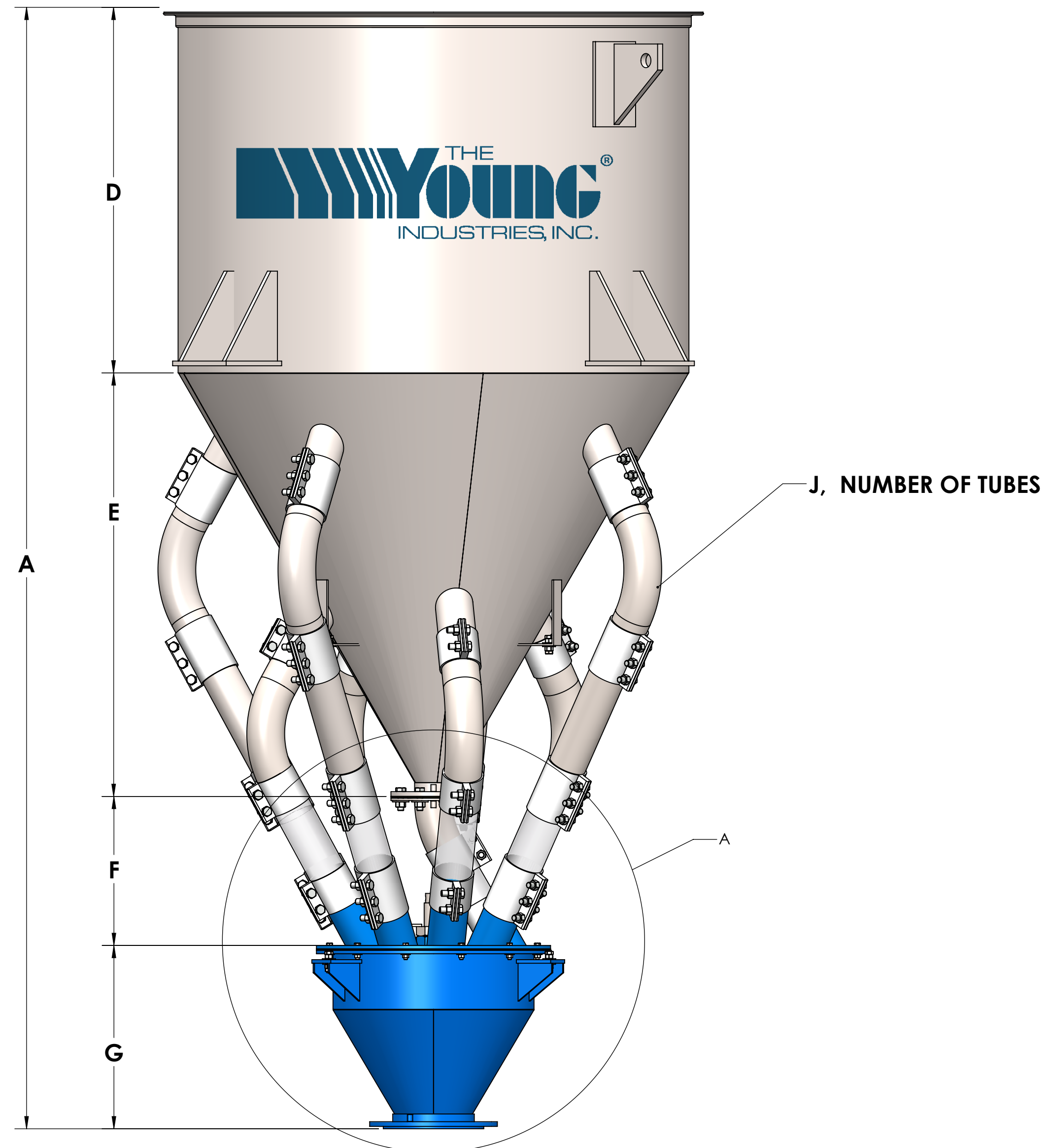

DETAIL A
SCALE 1 : 8

NOTES:

- LUCITE TUBE SECTIONS FINISHED WITH ALL UNITS.
- FOUR(4) SUPPORT LUGS FURNISHED STANDARD ON ALL BLENDERS
OTHER BIN SUPPORTS CAN BE FURNISHED ON REQUEST.
- UNITS SUPPLIED WITH OPEN TOP OR COVER AS REQUIRED.
- WHEN ORDERING, SPECIFY:
 - BLENDER SIZE (CU. FT. WORKING CAPACITY)
 - MATERIALS OF CONSTRUCTION(ALUM,S/S,C/S WITH EPOXY.)
 - BLENDING CHAMBER DISCHARGE SIZE.
 - TYPE OF TOP(OPEN OR COVER.)

REV. NO.	DESCRIPTION	DATE	BY
REVISIONS			
CUSTOMER:			
CUSTOMER PO NUMBER:			
YOUNG JOB NUMBER:			
TITLE			
HOPPER TYPE, MULTI-PORT, GRAVITY BLENDER MP-1			
THE YOUNG INDUSTRIES, INC. MUNCY, PENNSYLVANIA 17756 TELEPHONE: 570-546-3165			
DRAWN BY: SLB		DATE: 12/18/20	
CHECKED BY:		SCALE=1:6	
DRAWING NUMBER MP-1 S-4-3787-1		SHEET 1 OF 1	REV: 00

GENERAL TOLERANCES			
UNLESS OTHERWISE SPECIFIED THE FOLLOWING SHALL APPLY			
MACHINING - .XX=	.02	.XXX=	.005
ANGLE= .50°			
SURFACE ROUGHNESS HEIGHT 63 MICRORINCHES OR LESS			
FABRICATION - UNDER 6	6 TO 24	24 TO 60	OVER 60
± .06	± .12	± .19	± .25
UNLESS OTHERWISE SPECIFIED DIMENSIONS ARE IN INCHES			