

**ROUND INLET & OUTLET FLANGE DETAIL**  
SIZES 4" THRU 8" ONLY  
150# ANSI DRILLING

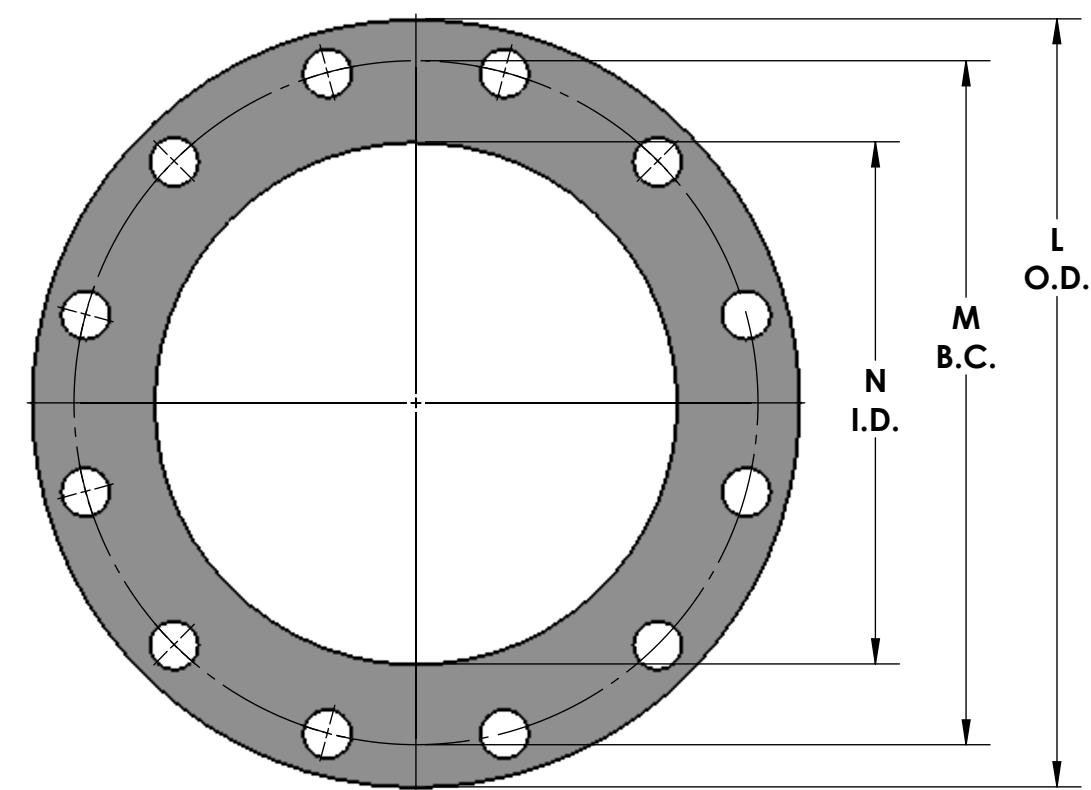

**ROUND INLET & OUTLET FLANGE DETAIL**  
SIZES 10" THRU 16" ONLY  
150# ANSI DRILLING

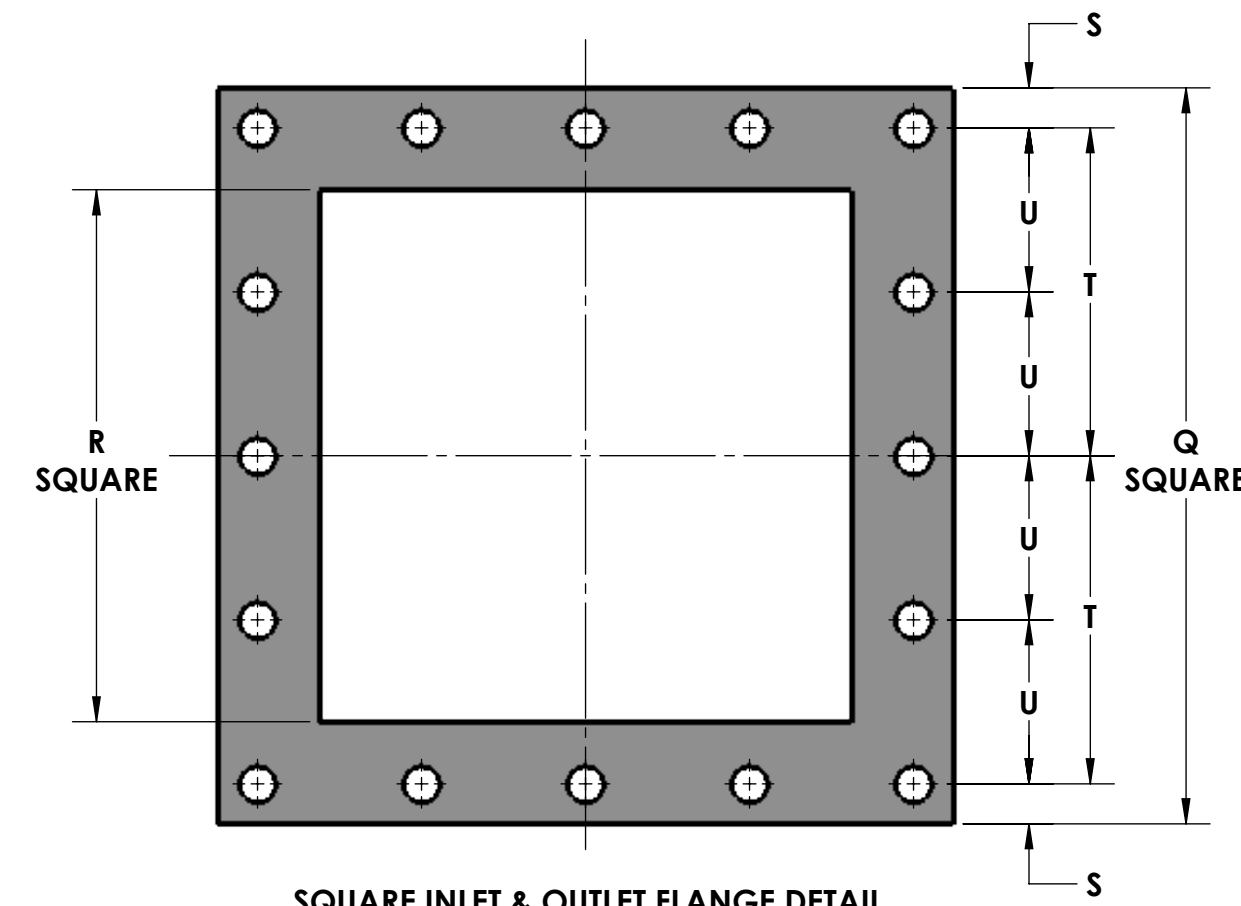

**SQUARE INLET & OUTLET FLANGE DETAIL**

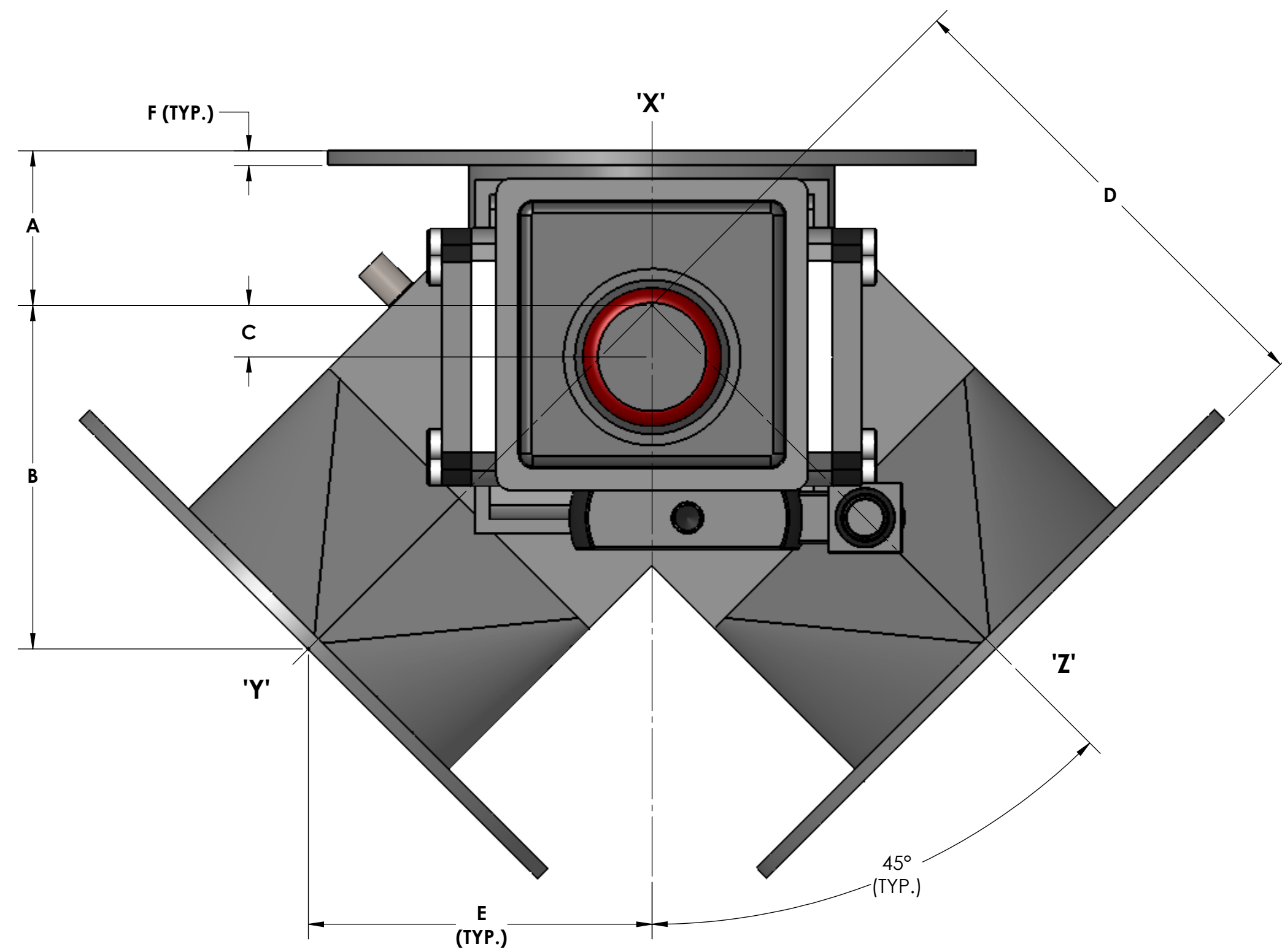
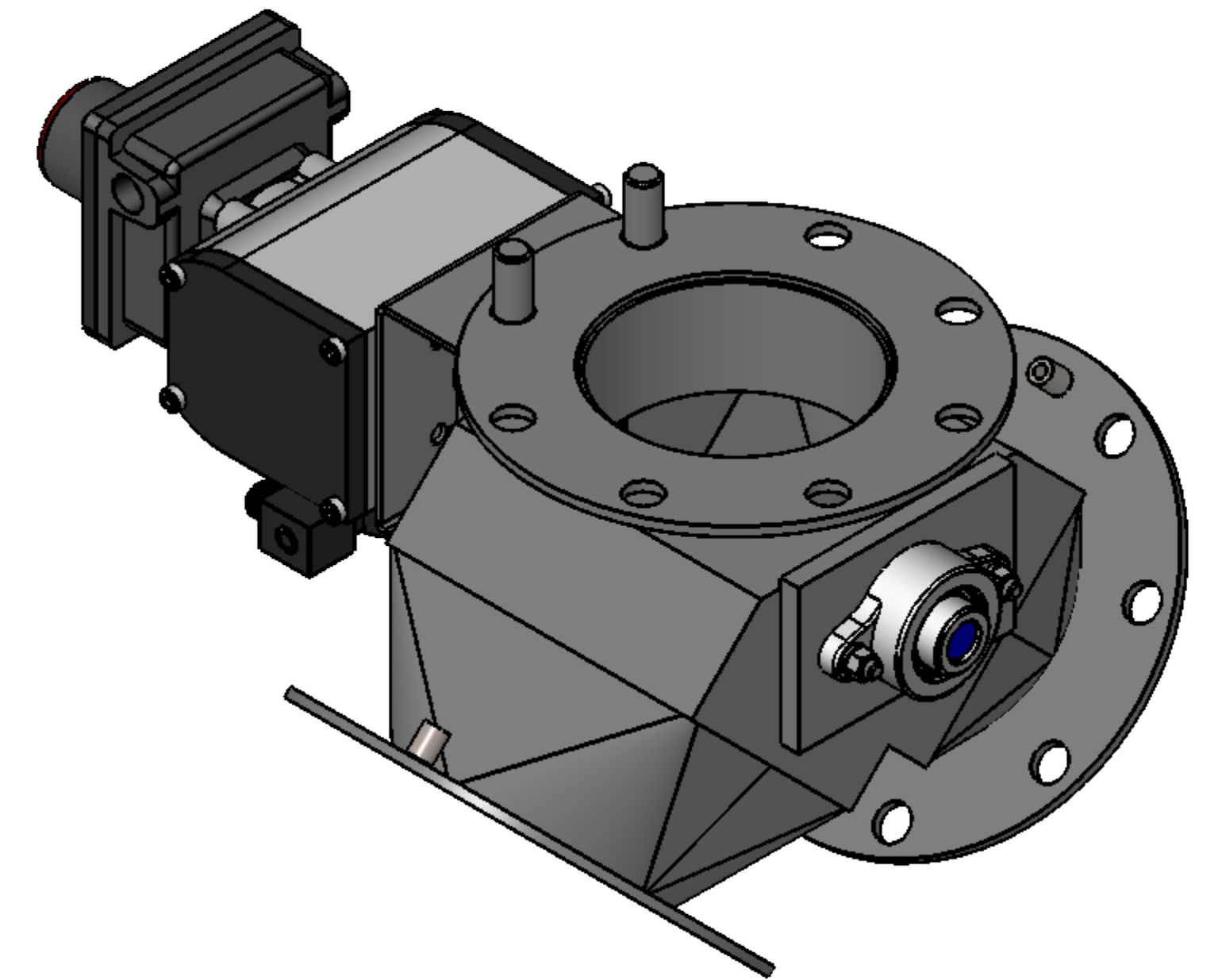

NOTE:  
ALLOW CLEARANCE FOR  
SWITCH COVER REMOVAL

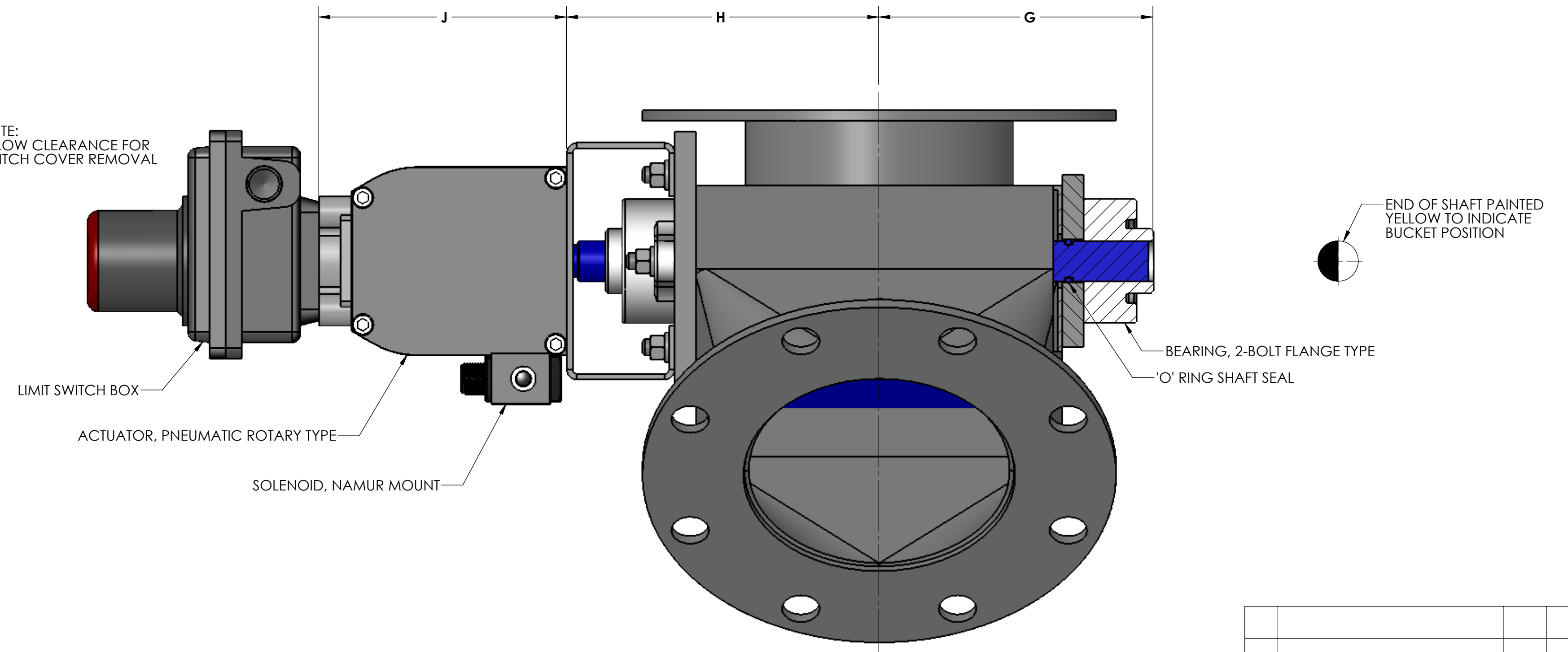

END OF SHAFT PAINTED  
YELLOW TO INDICATE  
BUCKET POSITION

CERTIFICATION	
CUSTOMER:	CUSTOMER NO:
	Y.I. ORDER NO:
	QUANTITY:
MATERIALS OF CONSTRUCTION:	SOLENOIDS:
HOUSING:	TYPE:
SIDE PLATES:	VOLTAGE:
GATE:	ENCLOSURE:
SHAFT:	
SEAL MATERIALS:	LIMIT SWITCHES:
HOUSING:	TYPE:
GATE:	
SHAFT:	ENCLOSURE:
TYPES OF ENDS:	REMARKS:
X:	
Y:	
Z:	
DIMENSIONS ON THIS DRAWING ARE CERTIFIED CORRECT FOR THIS ORDER	
PER:	DATE:
VALVE IS DESIGNED FOR 15 PSIG (MAX) INTERNAL & DIFFERENTIAL PRESSURE @250°F	

Size	A	B	C	D	E	F	G	H	J	L	M	N	P	Q	R	S	T	U	V
4	2.88	7.06	.50	10.00	7.06	.25	4.94	5.44	5.59	9.00	7.50	4.00	.75	7.50	4.00	.62	3.12	-	8
5	2.75	7.06	.56	10.00	7.06	.25	5.44	5.94	5.59	10.00	8.50	5.00	.88	8.50	5.00	.62	3.62	-	8
6	2.38	7.62	.88	10.75	7.62	.25	5.94	6.44	5.59	11.00	9.50	6.00	.88	9.50	6.00	.62	4.12	-	8
8	2.38	7.75	1.25	11.00	7.75	.38	6.94	7.44	5.59	13.50	11.75	8.00	.88	11.50	8.00	.62	5.12	2.56	16
10	2.38	9.18	1.75	13.00	9.18	.38	7.94	8.44	5.59	16.00	14.25	10.00	1.00	14.75	10.00	1.00	6.38	3.19	16
12	2.38	9.38	2.00	13.25	9.38	.38	8.94	9.44	5.59	19.00	17.00	12.00	1.00	16.75	12.00	1.00	7.38	3.69	16

SPECIFICATIONS ARE SUBJECT TO CHANGE WITHOUT NOTIFICATION

**NOTES:**

- VALVES ARE OF FABRICATED CONSTRUCTION AND AVAILABLE IN STEEL, ALUMINUM OR STAINLESS STEEL
- VALVES ARE AVAILABLE WITH ROUND OR SQUARE FLANGED ENDS, OR PLAIN ENDS

GENERAL TOLERANCES	
UNLESS OTHERWISE SPECIFIED THE FOLLOWING SHALL APPLY	
MACHINING - .XX=	.XX= .005 ANGLE= .50°
SURFACE ROUGHNESS HEIGHT 63 MICRONS OR LESS	
FABRICATION - UNDER 6	6 TO 24 24 TO 60 OVER 60
	± .06 ± .12 ± .19 ± .25
UNLESS OTHERWISE SPECIFIED DIMENSIONS ARE IN INCHES	

REV. NO.	DESCRIPTION	DATE	BY
REVISIONS			
CUSTOMER:			
CUST. NO.:			
YOUNG ORDER NO.:			
TITLE			
YOUNG INDUSTRIES VALVE, MODEL 'BDV', 45 DEGREE, W/ PNEUMATIC ACTUATOR, STANDARD DIMENSION SHEET			
MUNICIPALITY, PENNSYLVANIA 17756			
TELEPHONE: 570-546-3165			
DRAWN BY: BMF	DATE DRAWN: 4/19/16		
CHECKED BY:	SCALE: 1:2		
DRAWING NUMBER	S-4-7509		REV: