

NOTE: THE INTENT OF THIS DRAWING IS TO SHOW STANDARD DIMENSIONS AND FEATURES. ACTUAL DIMENSIONS AND FEATURES MAY CHANGE DEPENDING ON THE APPLICATION REQUIREMENTS.

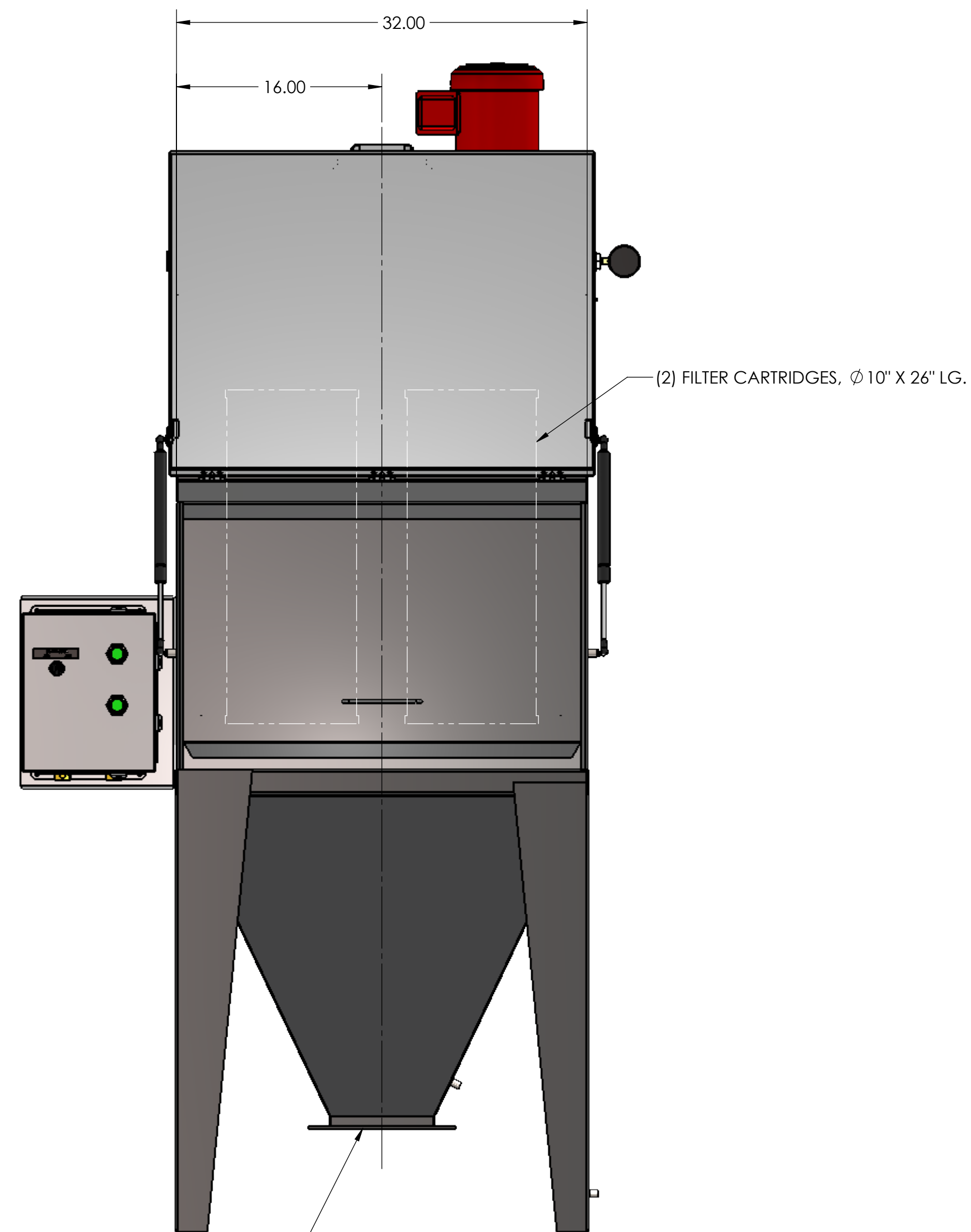

DISCHARGE FLANGE SIZE & LOCATION AS NEEDED

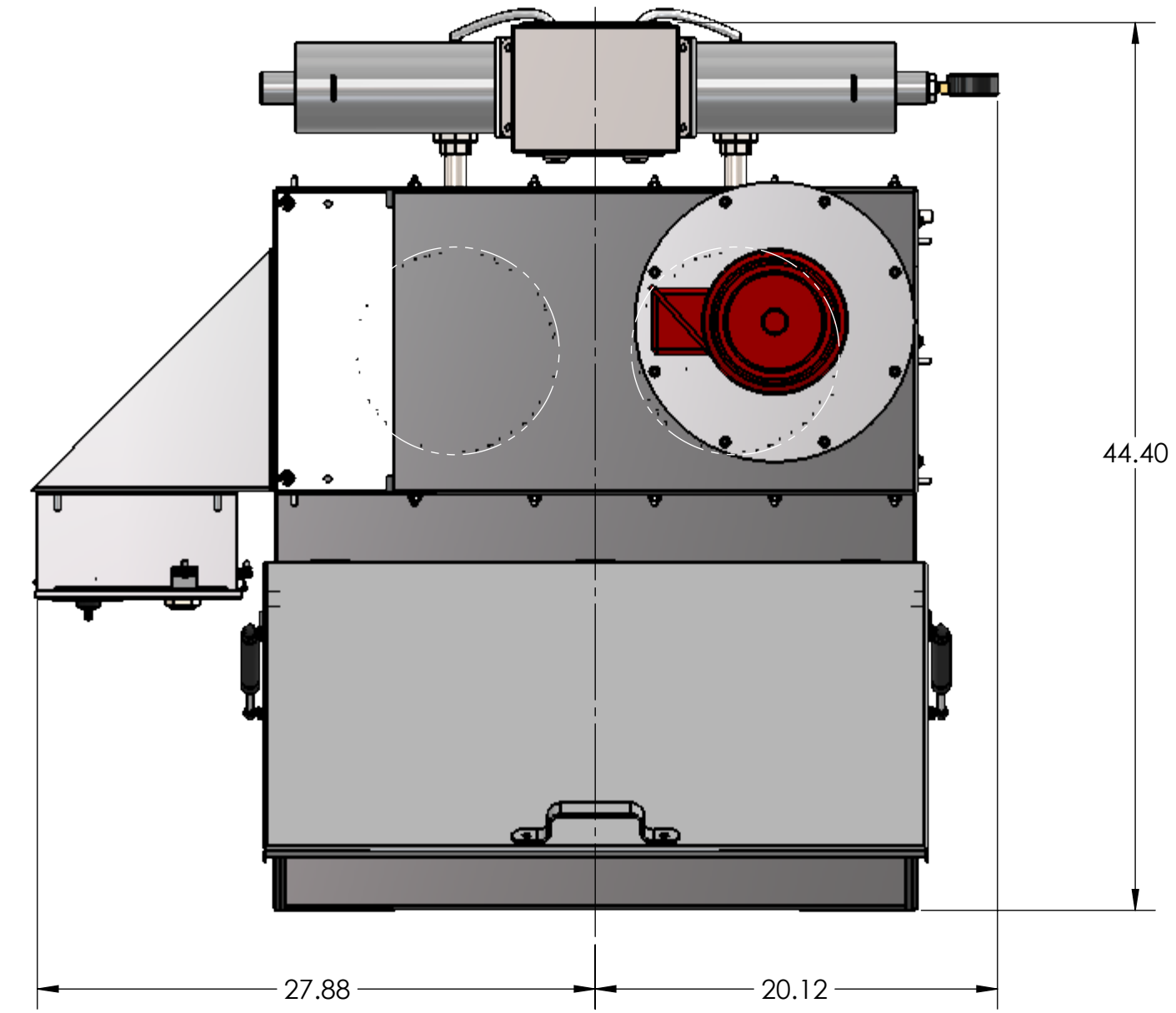
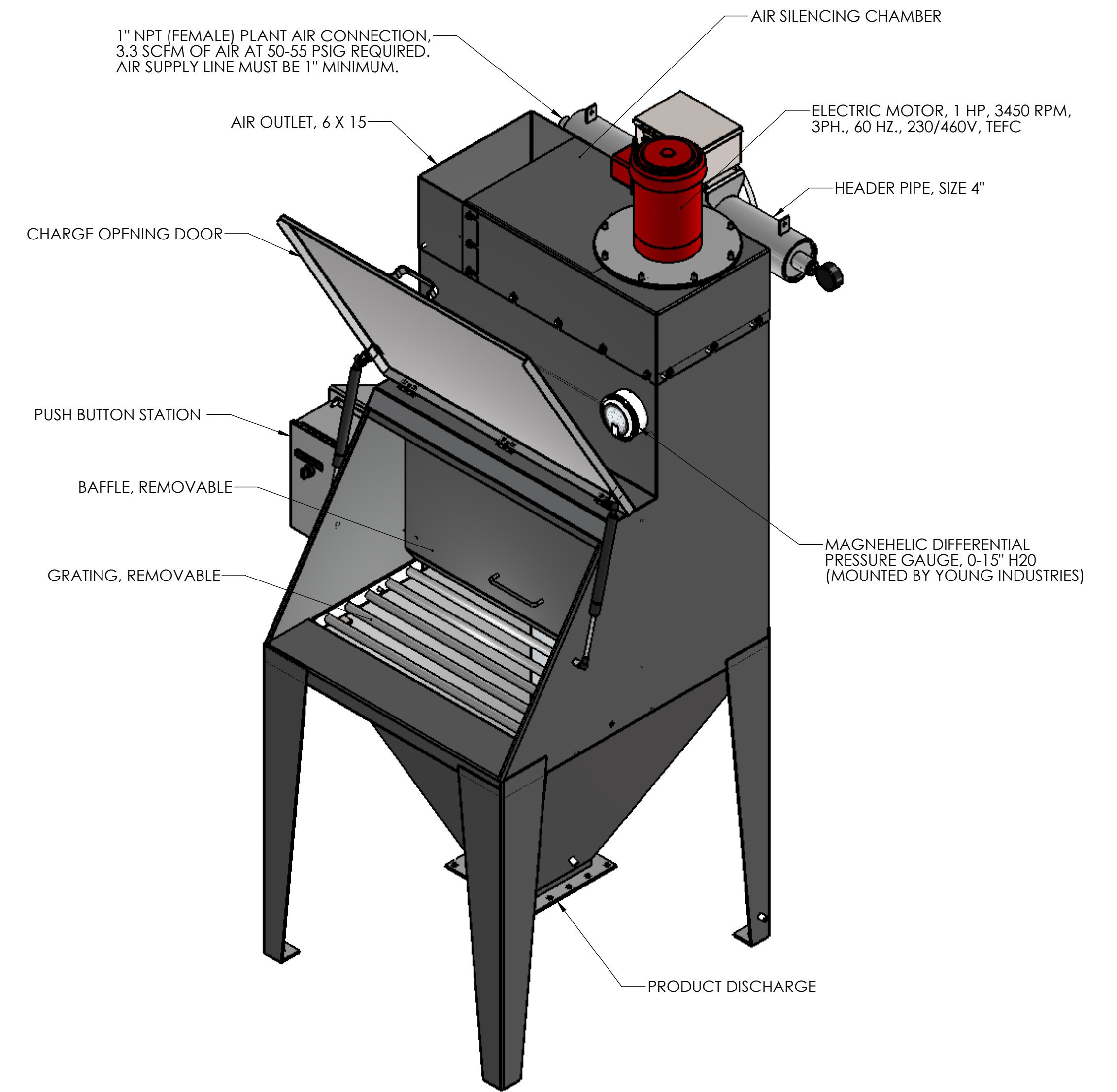
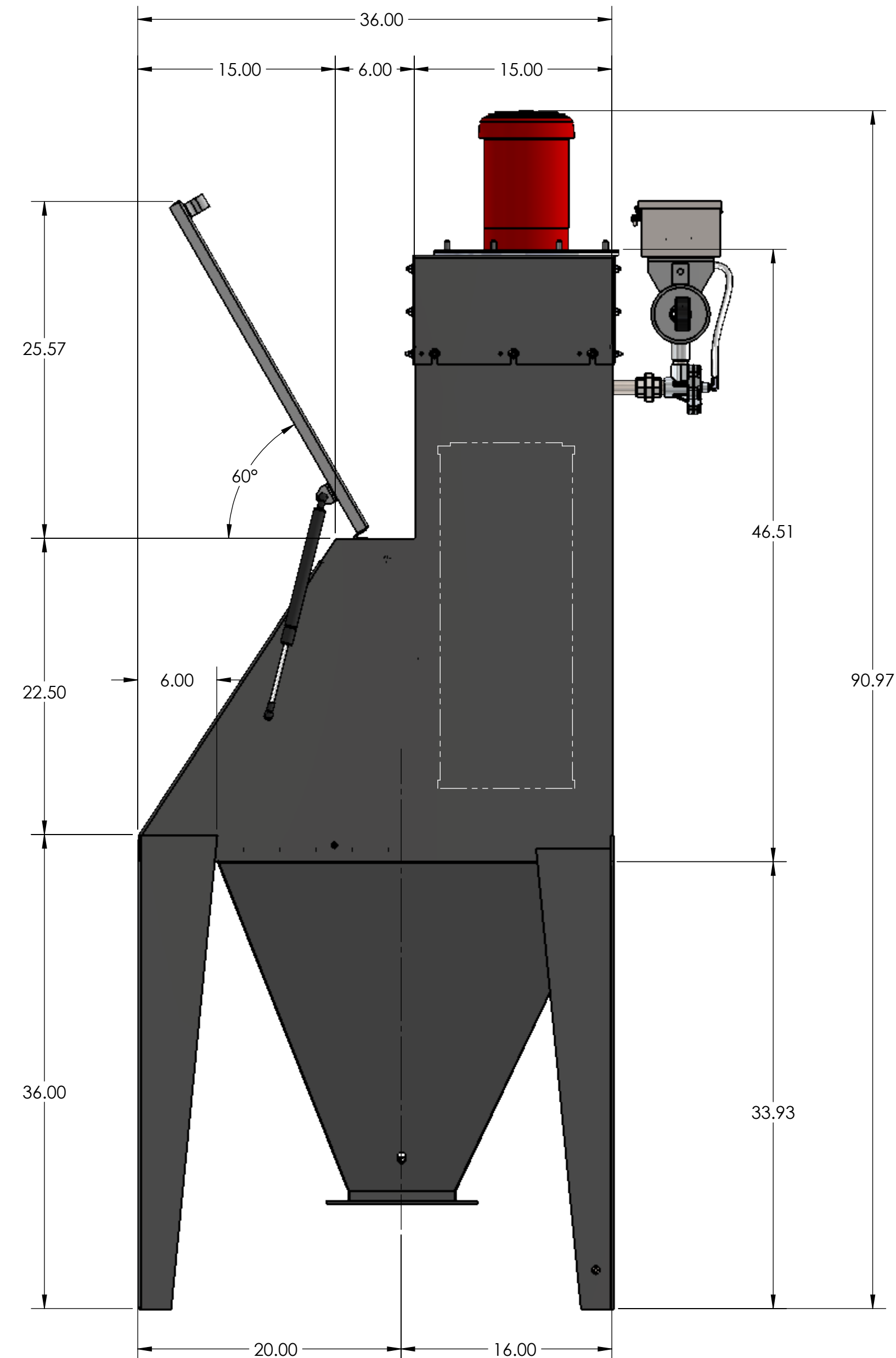

GENERAL TOLERANCES	
UNLESS OTHERWISE SPECIFIED THE FOLLOWING SHALL APPLY	
MACHINING - .XX= .02 .XXX= .005 ANGLE= .50°	
SURFACE ROUGHNESS HEIGHT 63 MICRONS OR LESS	
FABRICATION - UNDER 6 6 TO 24 24 TO 60 OVER 60	
± .06 ± .12 ± .19 ± .25	
UNLESS OTHERWISE SPECIFIED DIMENSIONS ARE IN INCHES	

UNIT WEIGHT
LBS

REV. NO.	DESCRIPTION	DATE	BY
REVISIONS			
CUSTOMER:			
CUSTOMER PO NUMBER:			
YOUNG JOB NUMBER:			
TITLE FILTER BAG DUMP STATION, HOPPER STYLE, MODEL FBD 10-2-C			
THE YOUNG INDUSTRIES, INC. HUNCY, PENNSYLVANIA 17756 TELEPHONE: 570-546-3165			
DRAWN BY: BMF		DATE DRAWN: 03/21/17	
CHECKED BY:		SCALE=1:8	
DRAWING NUMBER D-21012-00		SHEET 1 OF 1	REV: 00