

NOTE: THE INTENT OF THIS DRAWING IS TO SHOW STANDARD DIMENSIONS & FEATURES. ACTUAL DIMENSIONS & FEATURES MAY CHANGE DEPENDING ON APPLICATION REQUIREMENTS. NOT FOR FABRICATION.

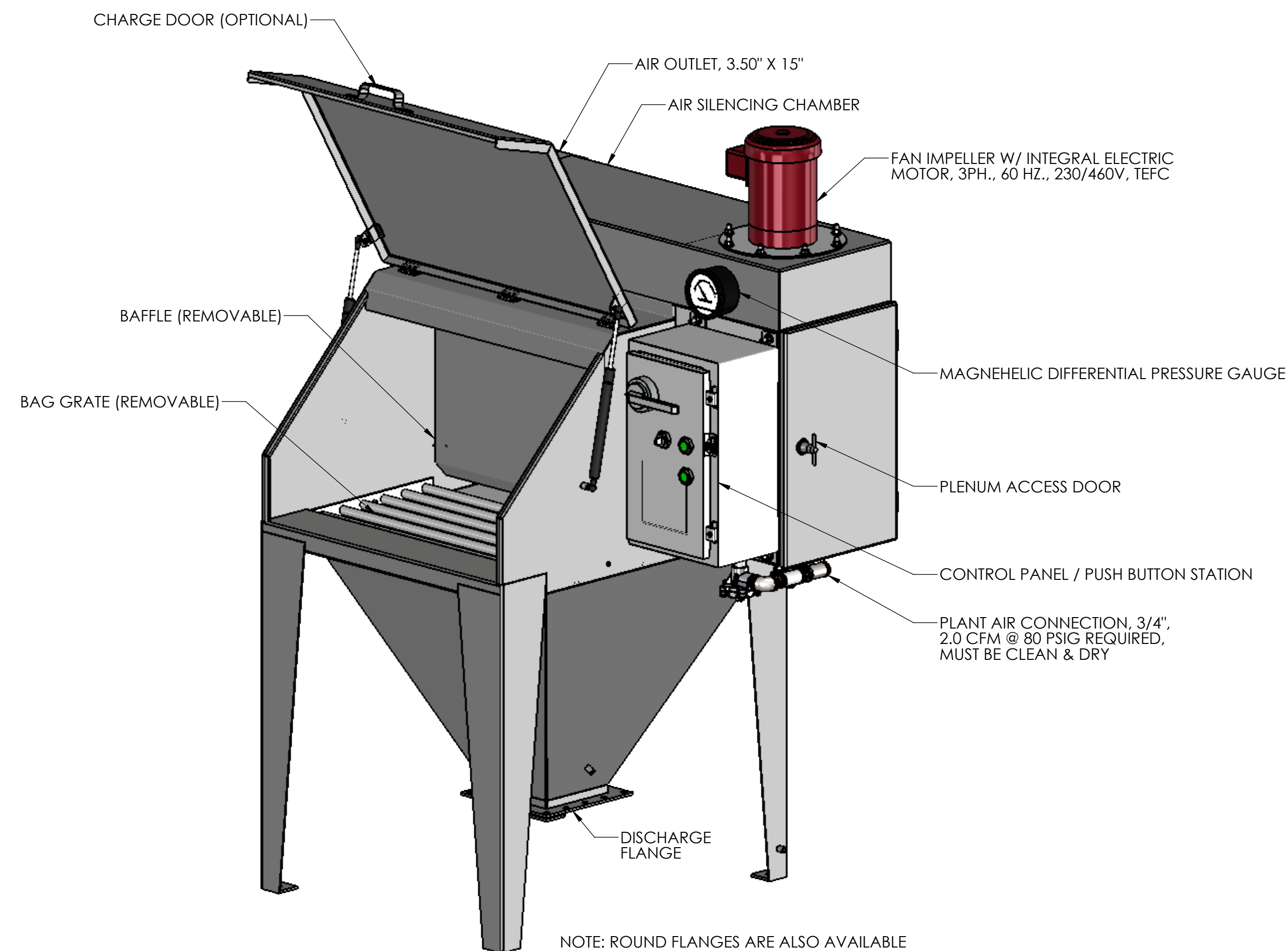
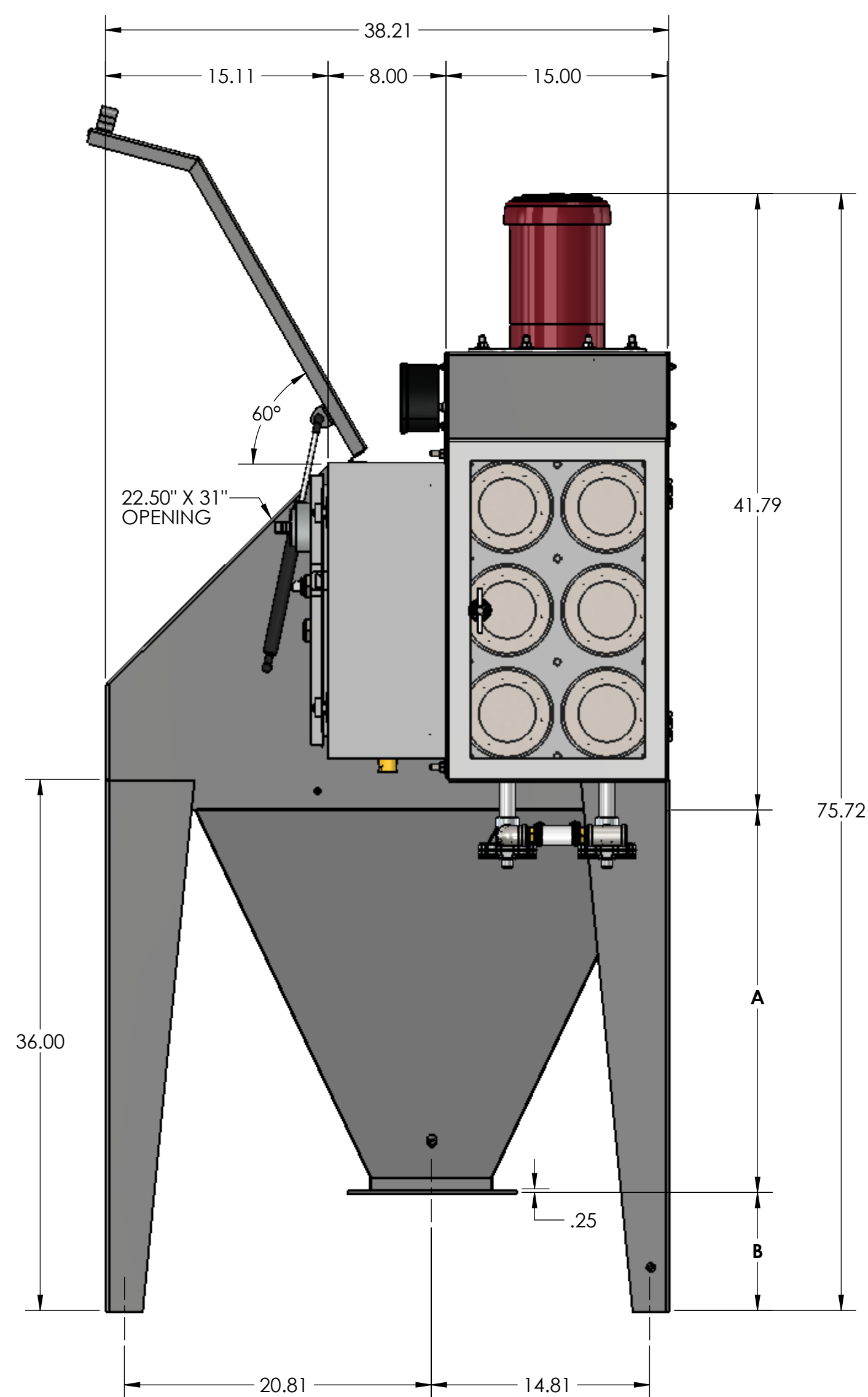
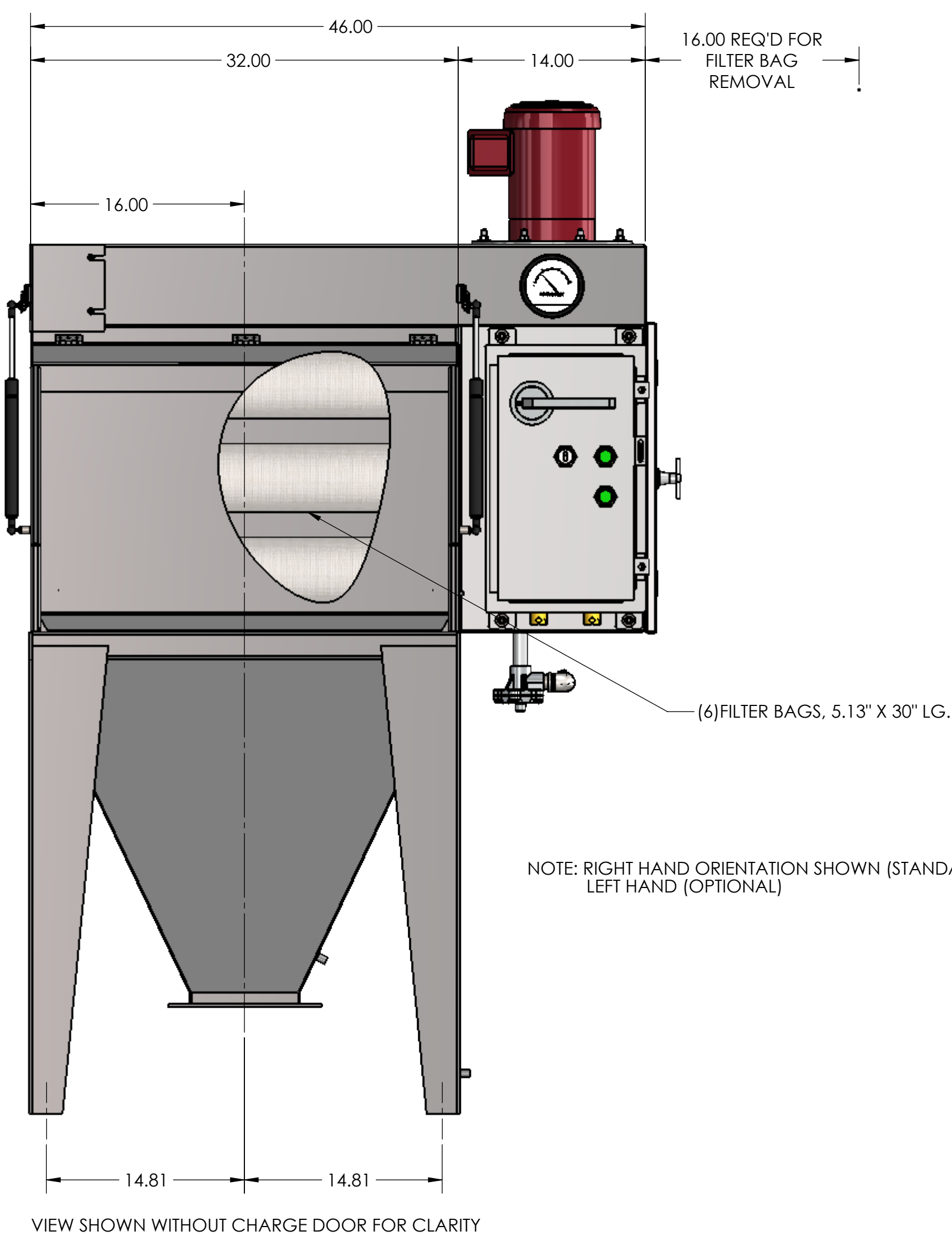
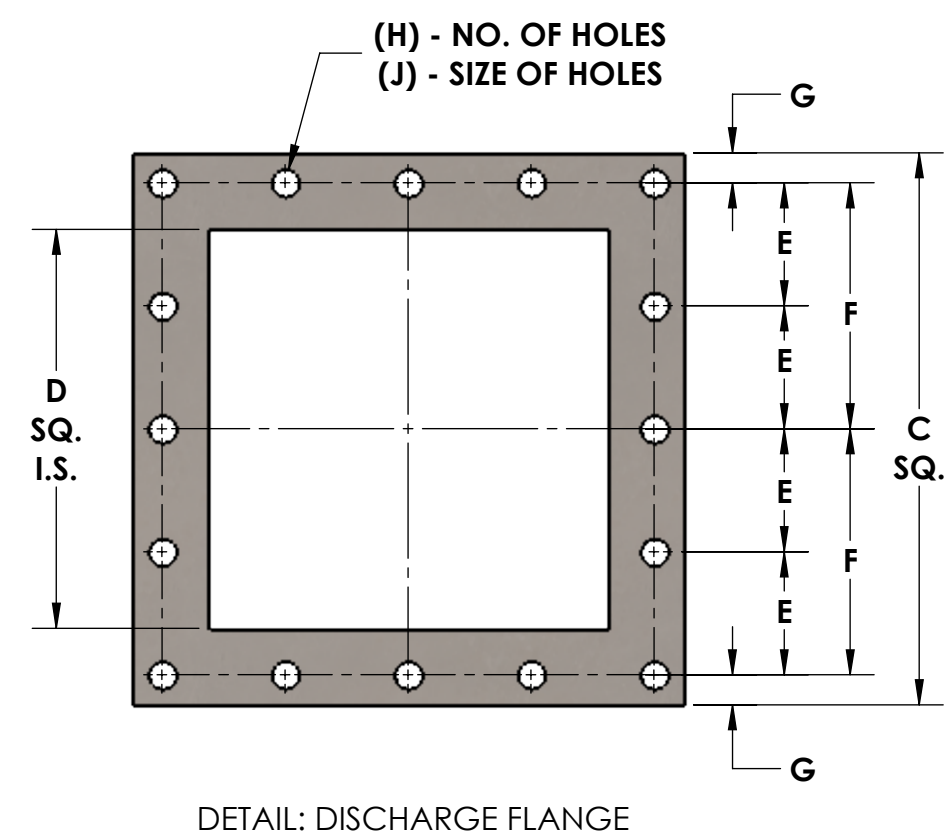
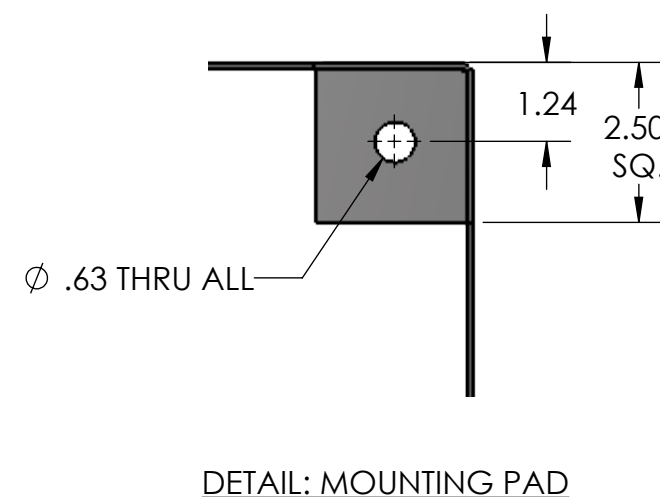

DISCHARGE FLANGE	A	B	C	D	E	F	G	H	J
6 X 6	27"	7"	9.5"	6"	-	4.12"	.62"	8	.56"
8 X 8	26"	8"	11.5"	8"	2.56"	5.12"	.62"	16	.56"
10 X 10	25"	9"	14.75"	10"	3.19"	6.38"	1"	16	.56"
12 X 12	25"	9"	16.75"	12"	3.69"	7.38"	1"	16	.56"

NOTE: SPECIFICATIONS SUBJECT TO CHANGE WITHOUT NOTIFICATION

GENERAL TOLERANCES	
UNLESS OTHERWISE SPECIFIED THE FOLLOWING SHALL APPLY	
MACHINING - .XX= .02 .XXX= .005 ANGLE= .50°	
SURFACE ROUGHNESS HEIGHT 63 MICRONS OR LESS	
FABRICATION - UNDER 6 6 TO 24 24 TO 60 OVER 60	
± .06 ± .12 ± .19 ± .25	
UNLESS OTHERWISE SPECIFIED DIMENSIONS ARE IN INCHES	

REV. NO.	DESCRIPTION	DATE	BY
REVISIONS			
CUSTOMER:			
CUSTOMER PO NUMBER:			
YOUNG JOB NUMBER:			
TITLE			
FILTER BAG DUMP STATION, HOPPER STYLE, MODEL FBD 30-6			
DRAWN BY: BMF		DATE: 05/15/19	
CHECKED BY:		SCALE=1:8	
DRAWING NUMBER		SHEET	REV:
S-21118-00		1 OF 1	00