

NOTE: THE INTENT OF THIS DRAWING IS TO SHOW STANDARD DIMENSIONS & FEATURES. ACTUAL DIMENSIONS & FEATURES MAY CHANGE DEPENDING ON THE APPLICATION REQUIREMENTS. NOT FOR FABRICATION.

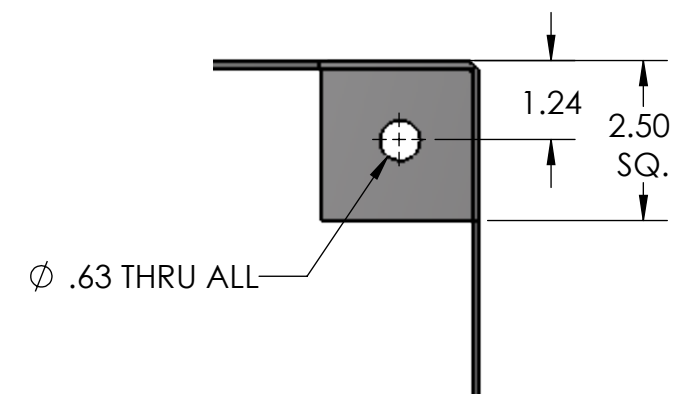

DETAIL: MOUNTING PAD

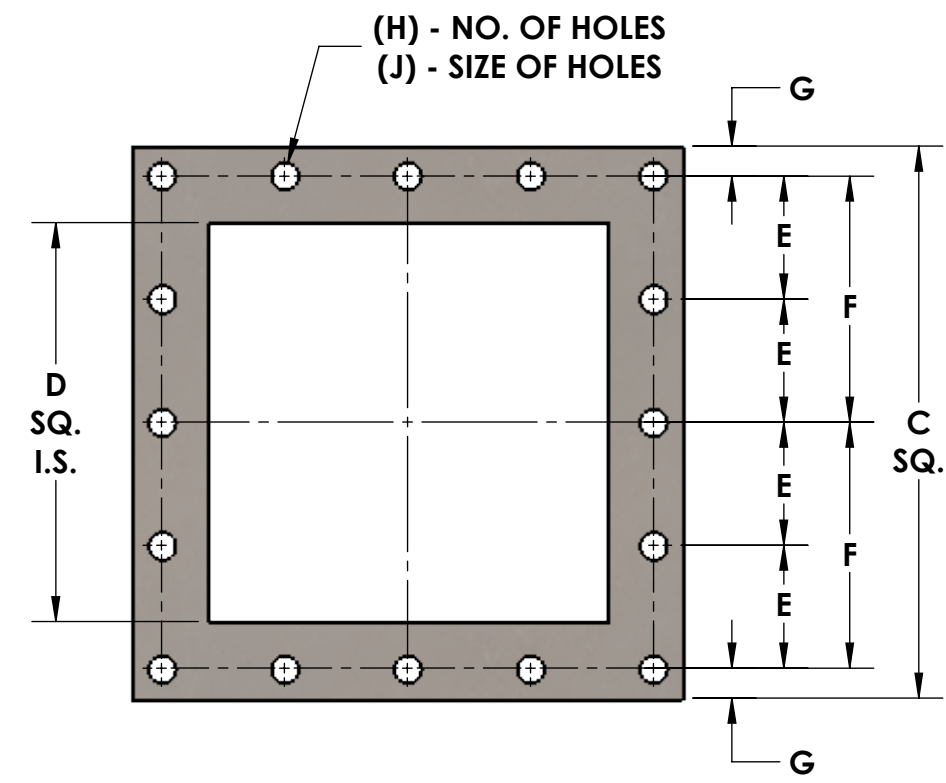

DETAIL: DISCHARGE FLANGE

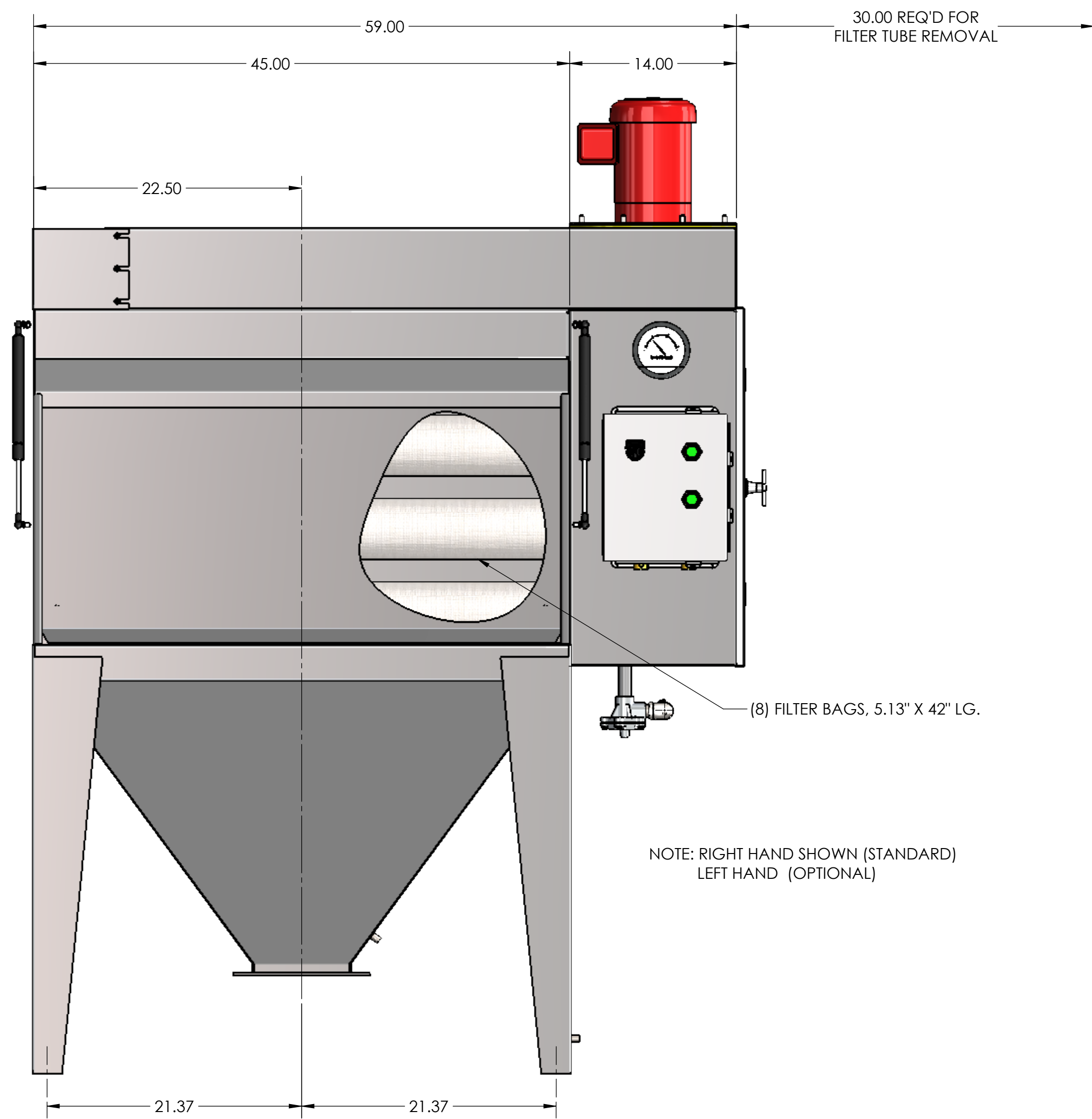

(8) FILTER BAGS, 5.13" X 42" LG.

NOTE: RIGHT HAND SHOWN (STANDARD)
LEFT HAND (OPTIONAL)

VIEW SHOWN WITHOUT CHARGE DOOR FOR CLARITY

DISCHARGE FLANGE	A	B	C	D	E	F	G	H	J
6 X 6	27"	7.25"	9.5"	6"	-	4.12"	.62"	8	.56"
8 X 8	26"	8.25"	11.5"	8"	2.56"	5.12"	.62"	16	.56"
10 X 10	25"	9.25"	14.75"	10"	3.19"	6.38"	1"	16	.56"
12 X 12	25"	9.25"	16.75"	12"	3.69"	7.38"	1"	16	.56"

NOTE: SPECIFICATIONS SUBJECT TO CHANGE WITHOUT NOTIFICATION

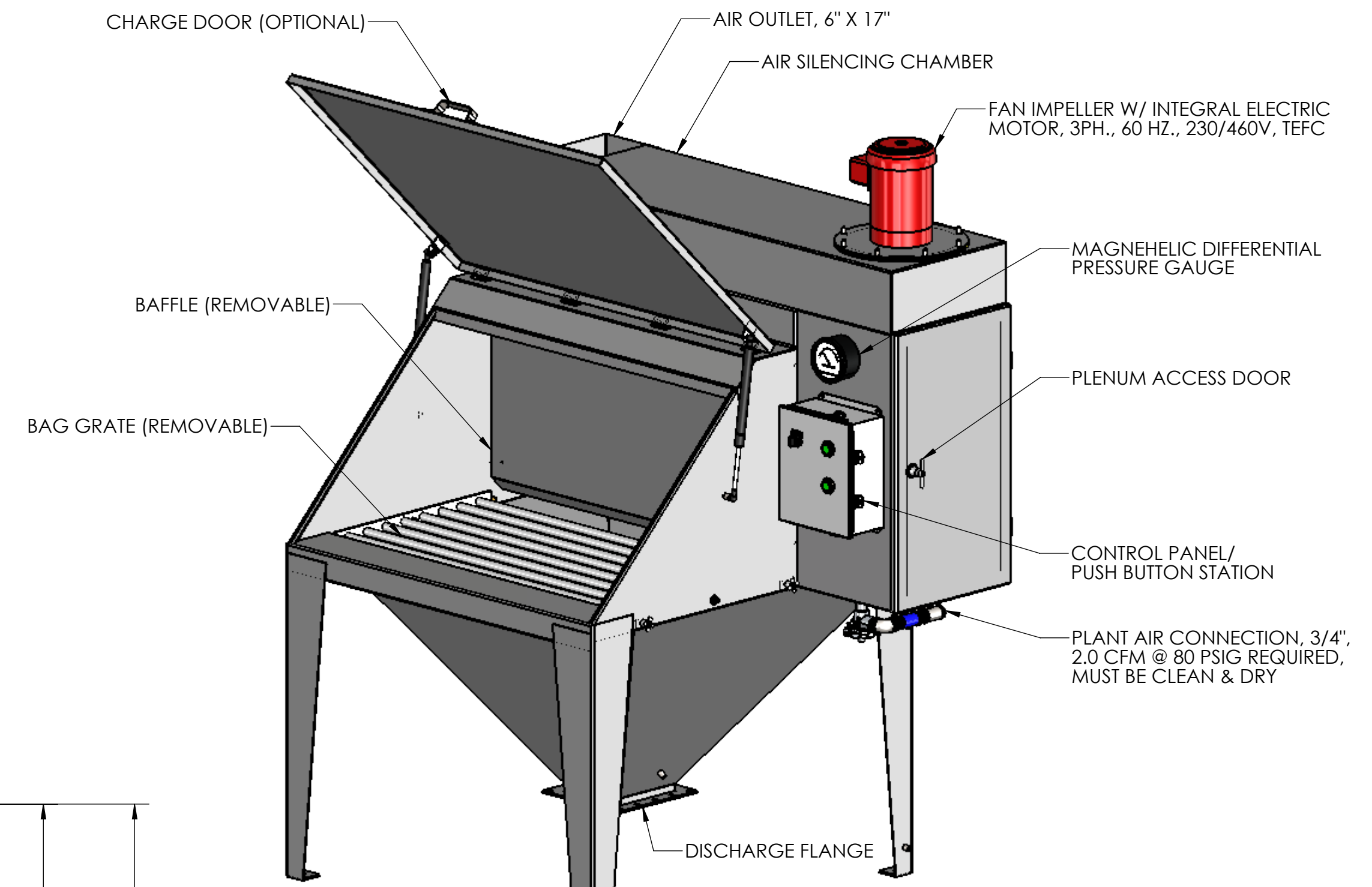
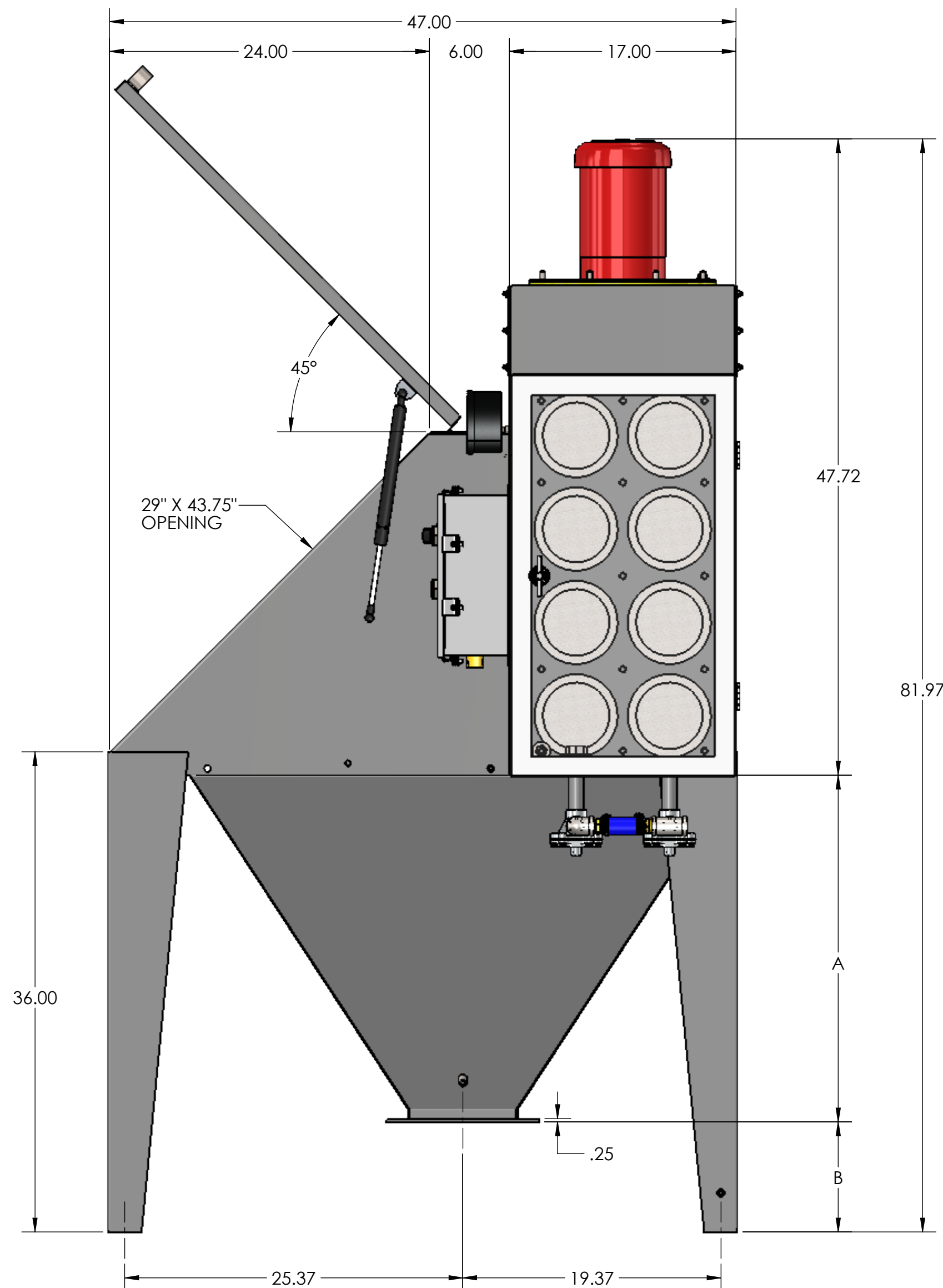

NOTE: ROUND FLANGES ARE ALSO AVAILABLE

REV. NO.	DESCRIPTION	DATE	BY
REVISIONS			
CUSTOMER:			
CUSTOMER PO NUMBER:			
YOUNG JOB NUMBER:			
TITLE			
FILTER BAG DUMP STATION, HOPPER STYLE, MODEL FBD 42-8			
 THE YOUNG INDUSTRIES, INC. MUNCY, PENNSYLVANIA 17756 TELEPHONE: 570-546-3165			
DRAWN BY: BMF		DATE: 3/29/18	
CHECKED BY:		SCALE=1:8	
DRAWING NUMBER		SHEET	
S-21118-01		1 OF 1	
		REV: 00	

GENERAL TOLERANCES	
UNLESS OTHERWISE SPECIFIED THE FOLLOWING SHALL APPLY	
MACHINING - .XX= .02 .XXX= .005 ANGLE= .50°	
SURFACE ROUGHNESS HEIGHT .63 MICRONS OR LESS	
FABRICATION - UNDER 6 6 TO 24 24 TO 60 OVER 60	
± .06 ± .12 ± .19 ± .25	
UNLESS OTHERWISE SPECIFIED DIMENSIONS ARE IN INCHES	