

NOTE: THE INTENT OF THIS DRAWING IS TO SHOW STANDARD DIMENSIONS & FEATURES. ACTUAL DIMENSIONS & FEATURES MAY CHANGE DEPENDING ON APPLICATION REQUIREMENTS. NOT FOR FABRICATION.

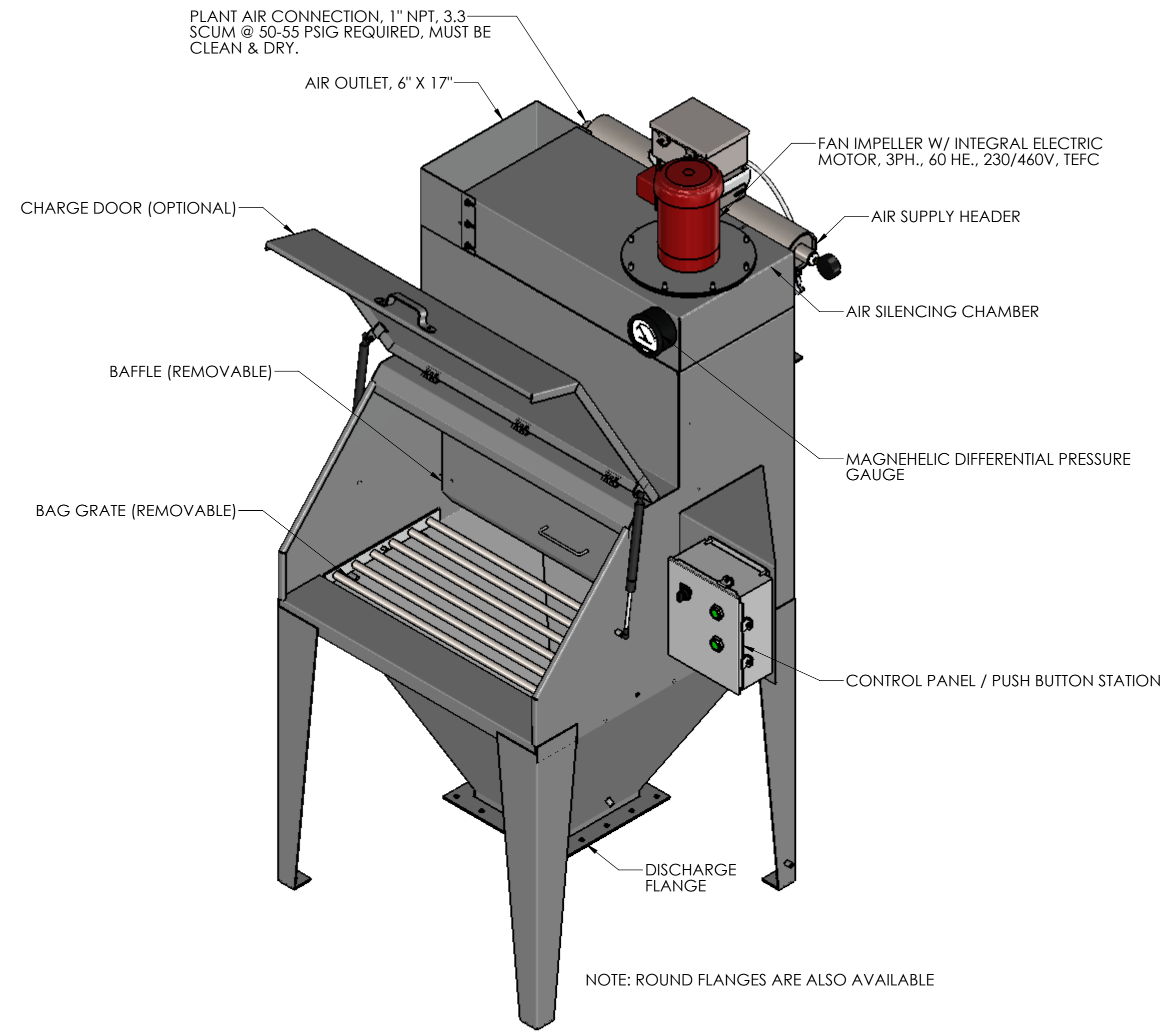

NOTE: ROUND FLANGES ARE ALSO AVAILABLE

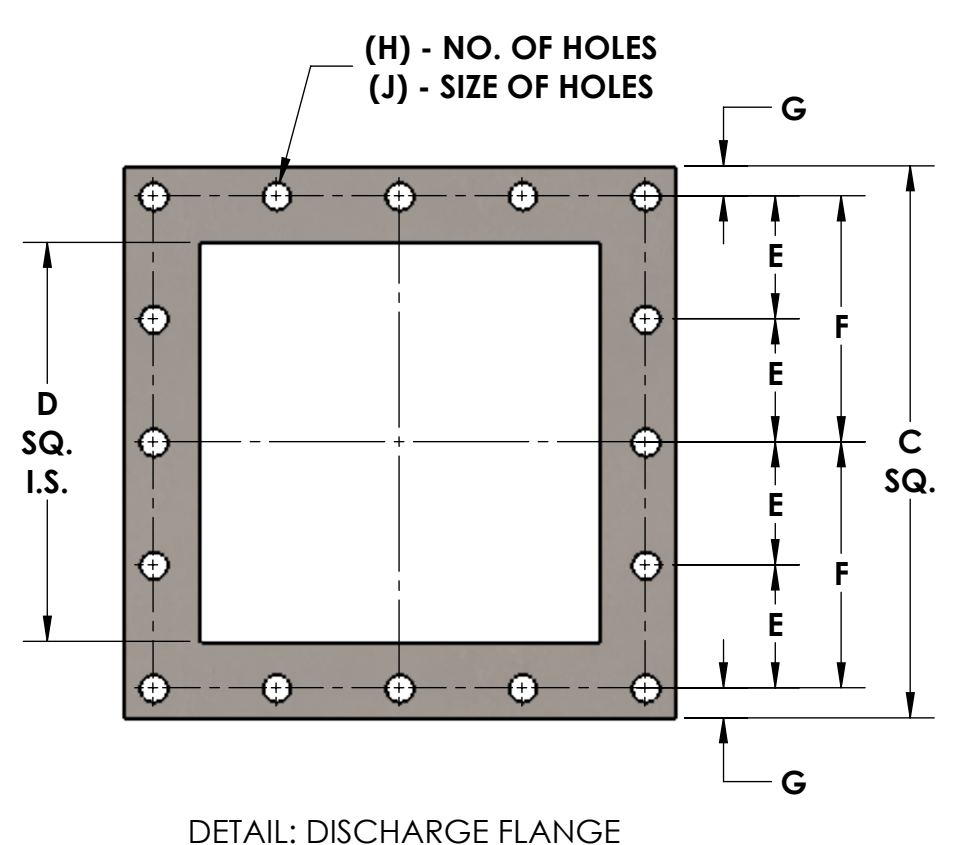
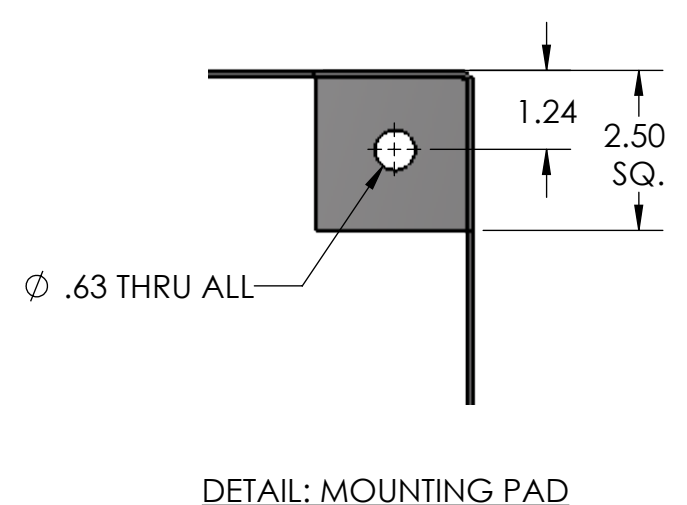
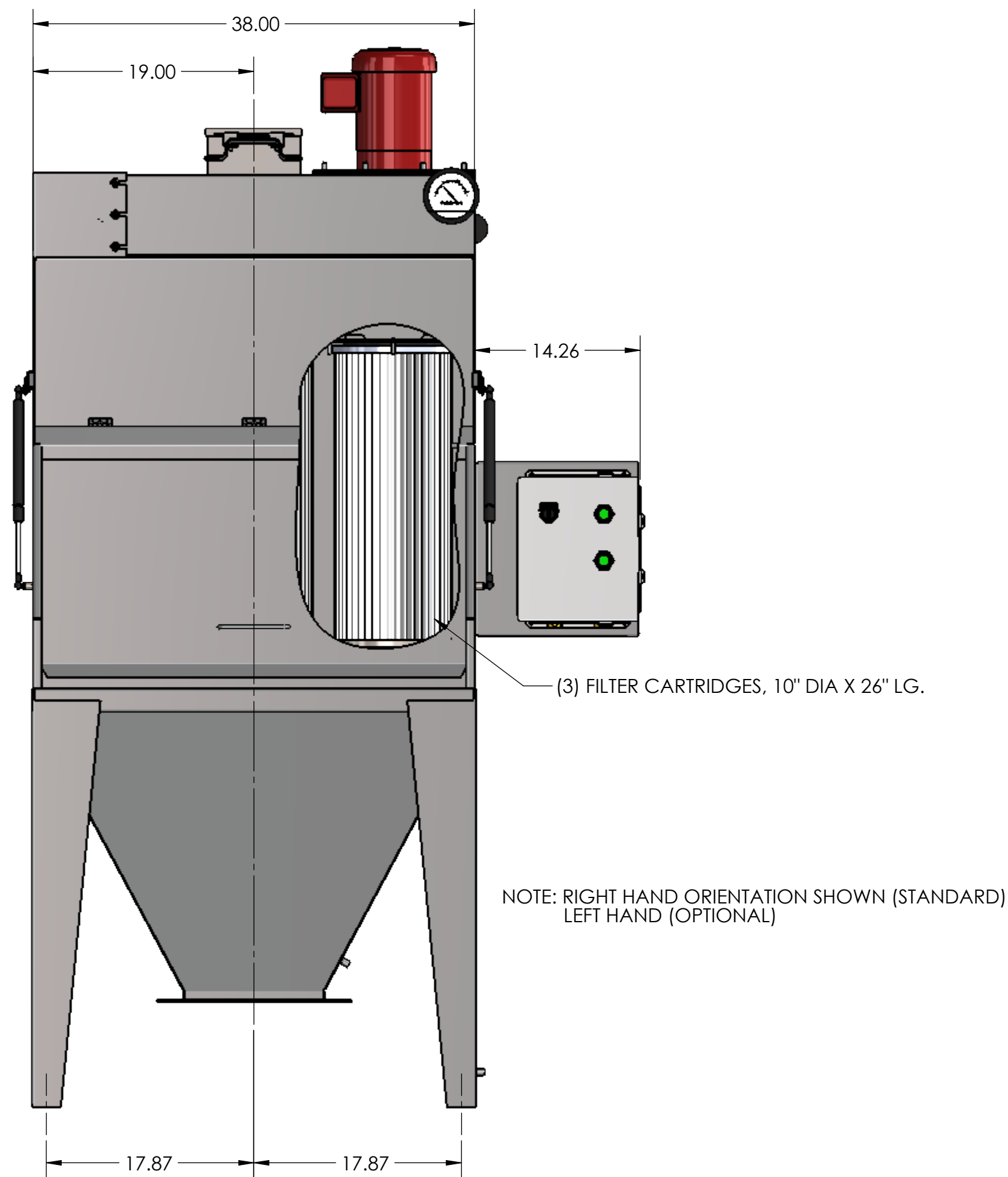

VIEW SHOWN WITHOUT CHARGE DOOR FOR CLARITY

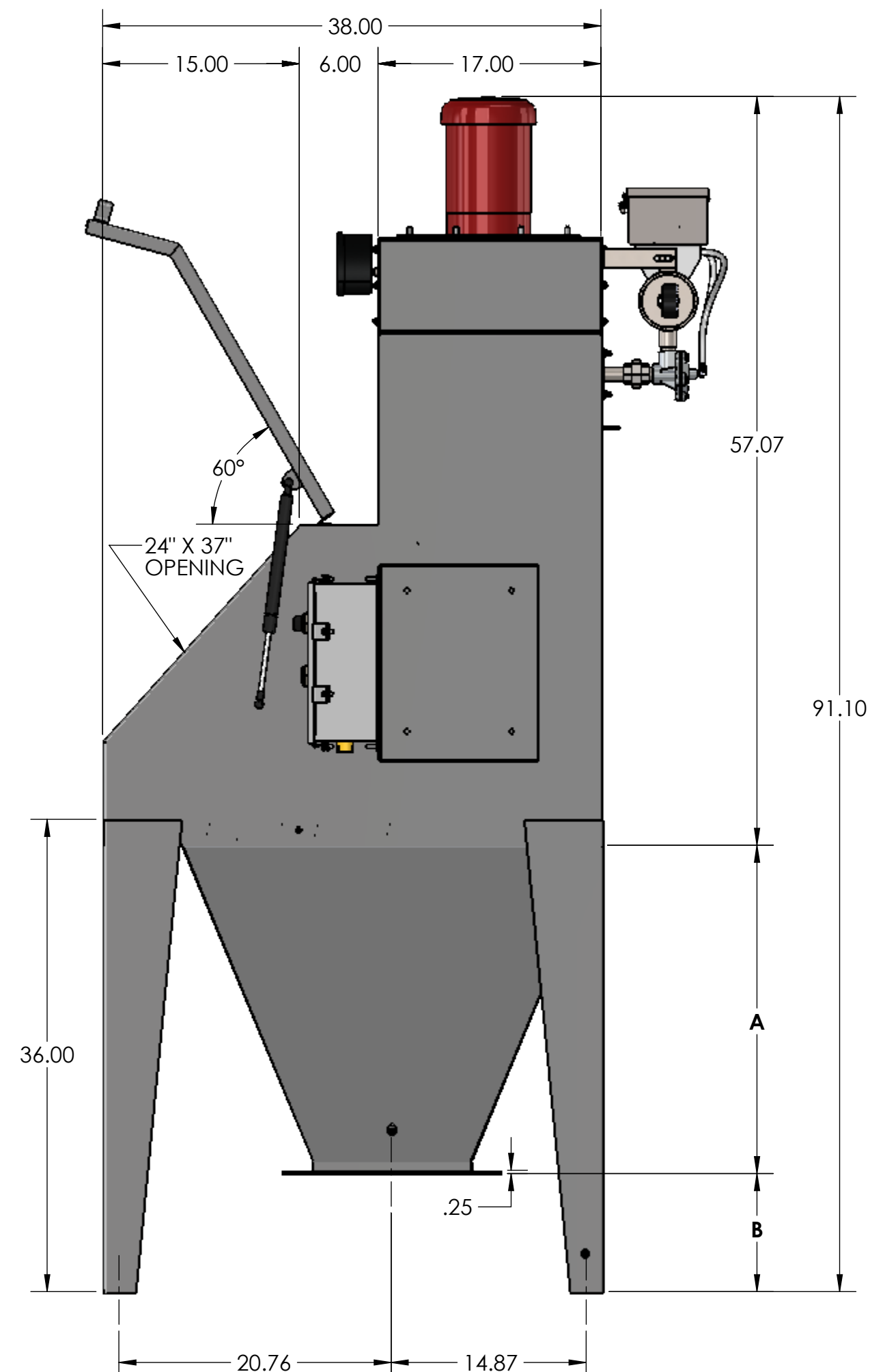

DISCHARGE FLANGE	A	B	C	D	E	F	G	H	J
6 X 6	27"	7"	9.5"	6"	-	4.12"	.62"	8	.56"
8 X 8	26"	8"	11.5"	8"	2.56"	5.12"	.62"	16	.56"
10 X 10	25"	9"	14.75"	10"	3.19"	6.38"	1"	16	.56"
12 X 12	25"	9"	16.75"	12"	3.69"	7.38"	1"	16	.56"

NOTE: SPECIFICATIONS SUBJECT TO CHANGE WITHOUT NOTIFICATION

REV. NO.	DESCRIPTION	DATE	BY
REVISIONS			
CUSTOMER:			
CUSTOMER PO NUMBER:			
YOUNG JOB NUMBER:			
TITLE			
FILTER BAG DUMP STATION, HOPPER STYLE, MODEL FBD 10-3-C			
 THE YOUNG INDUSTRIES, INC. MINICY, PENNSYLVANIA 17756 TELEPHONE: 570-546-3165			
DRAWN BY: BMF		DATE: 05/16/19	
CHECKED BY:		SCALE=1:10	
DRAWING NUMBER		SHEET	
S-21118-03		1 OF 1	
		REV: 00	

GENERAL TOLERANCES			
UNLESS OTHERWISE SPECIFIED THE FOLLOWING SHALL APPLY			
MACHINING	.XX	.XXX	.005
ANGLE= .50°			
SURFACE ROUGHNESS HEIGHT 63 MICRONS OR LESS			
FABRICATION	UNDER 6	6 TO 24	24 TO 60
	± .06	± .12	± .19
			± .25
UNLESS OTHERWISE SPECIFIED DIMENSIONS ARE IN INCHES			